

eltherm[®]
innovations in heat tracing



















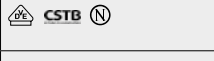

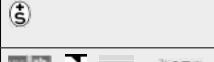



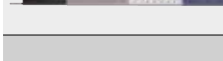
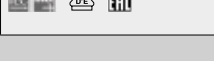



Self-regulating Parallel Heating Cables

innovations in heat tracing

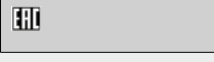

Table of Contents

Introduction				3-5
Application Options				6-7
1. Heating Cables				
	Type ELSR-N	Self-regulating Heating Cable up to 80 °C		8-9
	Type ELSR-LS	Self-regulating Heating Cable up to 80 °C		10-11
	Type ELSR-M	Self-regulating Heating Cable up to 65 °C		12-13
	Type ELSR-M-AF/BF	Self-regulating Heating Cable up to 65 °C		14-15
	Type ELSR-R	Self-regulating Heating Cable up to 65 °C		16-17
	Type ELSR-W	Self-regulating Heating Cable up to 100 °C		18-19
	Type ELSR-H	Self-regulating Heating Cable up to 210 °C		20-21
	Type ELSR-Ramp	Concrete and Ramp Heating Cable		22-23
	Type ELSR-FHP	Foundation Heating Cable		24-27
2. Measurement and Control				
	Type ELTC 05-Frostcontrol	Electronic Frost Protection Thermostat		28
	Type ELTC-14	Electronic Temperature Controller		29
	Type ELTC-21	Electronic Temperature Controller		30
	Type ELTC-22	Electronic Temperature Controller		31
3. Junction Boxes and Accessories				
	Junction Boxes / Connection Kits / Termination Kits			32-39
	El-Clic			40-41
	Junction Boxes / Connection Kits / Termination Kits for Hazardous Areas			42-51
	Accessories Overview			52-55
	Cable Overview			56-57
	Design Guide			58-59

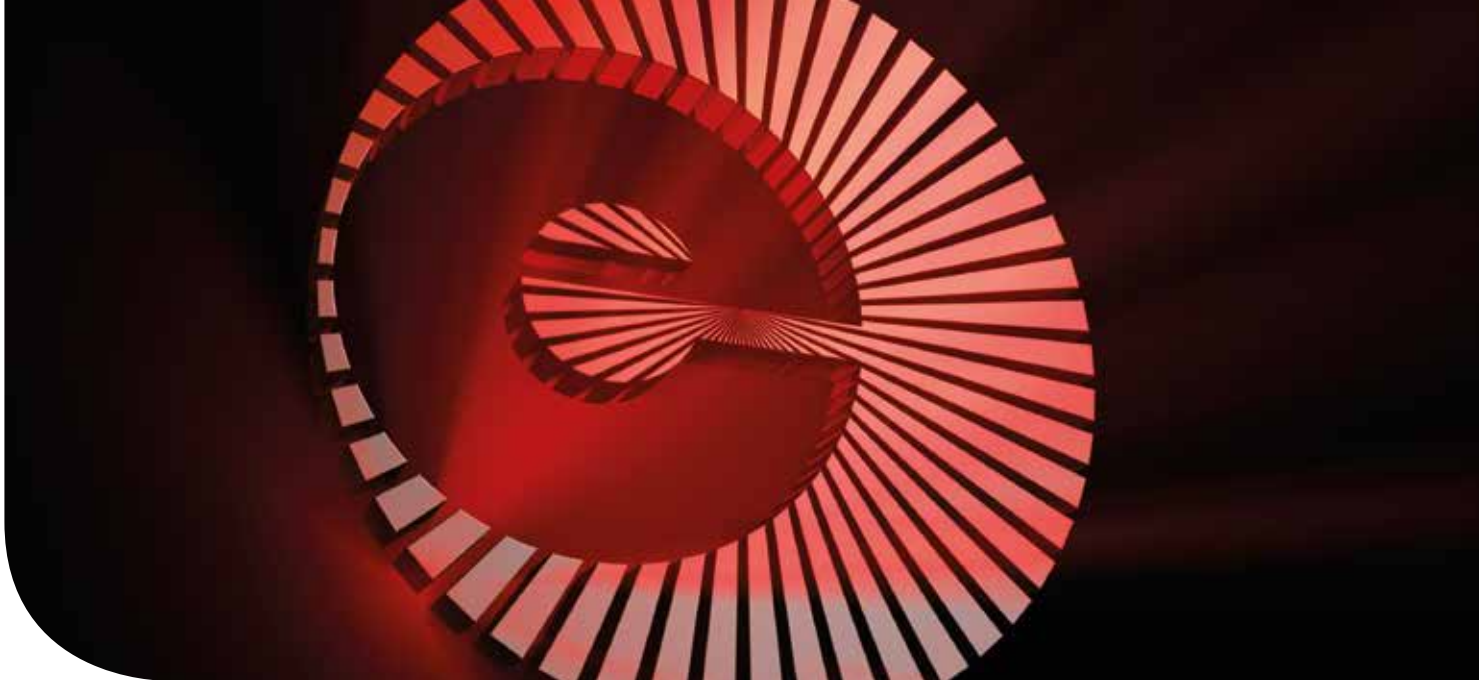

Important Information

Products marked with the -symbol can be used in hazardous areas. The temperatures allocated to the products are the maximum permissible exposure temperatures. Our project engineers will be glad to assist you to design and dimension electrical heating systems. A project design guide is included, helping you to collect operating data as well as marking correct dimensioning and allocation possible. You can use the tables and the example for application to make your own design.

All products listed in the catalogue are available ex stock (subject to prior sale).

Furthermore, please note:

- All products listed in this catalogue shall only be connected and commissioned by a qualified electrician.
- All applicable local electrical and safety regulations must be observed during installation and operation.
- For economic reasons and for precise maintenance of a constant temperature we recommend the use of a temperature control unit.
- According to EN 62395-1, respectively EN 60519-10, residual current devices (RCDs) shall be used to separate in time electrical heating from the mains and to prevent consequential damages.

Specifications and advertising messages in this products and services catalogue, irrespective of their nature, in particular descriptions, illustrations, drawings, samples, information pertaining to quality, condition, composition, performance, consumption and usability as well as dimensions and weights of the product range remain subject to change in as far as they are not expressly declared as binding. They do not denote any assurance or guarantee whatsoever. Minor deviations from the product specifications shall be deemed approved in as far as they are not unreasonable for the buyer.

We explicitly reserve the right to amend errors and alter technical data.

Further documents are available with information about our high-quality products:

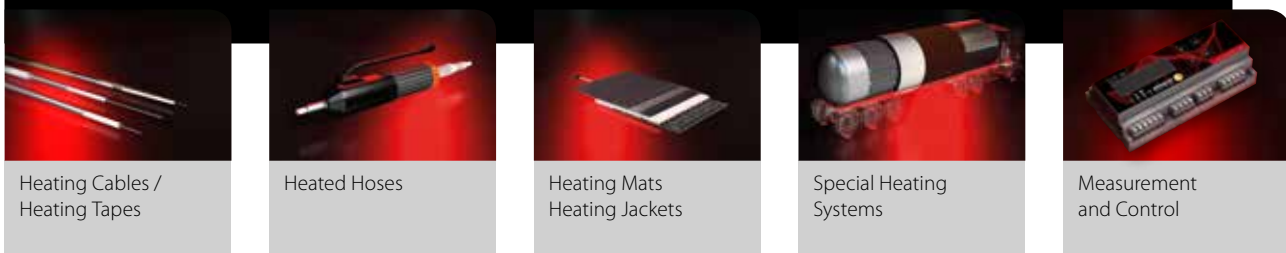

 Coil ware	 ESTI: Approval for the Swiss market	 NEMKO: Approval for the Norwegian market
 Suitable for contact with foodstuffs/approved for use in potable water	 EAC: Approval for the Russian market	 NEPSI: Hazardous Area Products for Chinese Market
 Certified according to VDE standards	 Approval for the French market	 KTL: Korean Testing Laboratory for Hazardous Area Products
 Ship Classification Maritime Service	 IECEx: Certified according to IECEx-scheme	 Expolabs: Approval for the South-African Market (Ex, IA approval)
 INMETRO: Approval for the Brazilian market	 Hyg, DVGW, KTW: Certification Body, Approval for Usage in Drinking Water	 ABS: American Bureau of Shipping - Product Design Assessment Certificate

Self-regulating Parallel Heating Cables

Attributes:

- Self-regulating with adaptable output
- Various temperature range applications
- Demand-orientated output grading
- High chemical resistance
- No temperature limitation required (important advantage as regards Ex-applications)
- Easy to lay and to install
- Can be cut to length off the roll
- Connection with plug-in connectors

Application:

The ELSR (**el**therm-**self**-regulating) heating cable can be used for frost protection and maintaining constant temperatures on vessels, pipes, valves, etc.. Except for the connections, the heating cable may be immersed to fluids. If used in an aggressive environment (the chemical or petrochemical industry), we lag the heating cable with a special chemically resistant outer jacket (fluoropolymer), option "BOT".

Function:

Self-regulating heating cables consist of two parallel bus wires embedded in a networked plastic heating element, doped with surrounding carbon particles. If the temperature increases during operation, the plastic expands due to molecular expansion and the distance between the carbon particles increases. Resistance increases and output drops. When it cools down, this process is reversed and output increases.

This physical property not to exceed the specified temperatures also facilitates the cross-routing of self-regulating cables and managing without a temperature cut-out device.





Features

Type	Self-regulating	Moisture proof	UV-resistant	Highest chemical resistance	Physical contact with foodstuffs / use in potable water	Low temperature	Medium temperature	High temperature	CE-approved for hazardous areas
ELSR-N-AO	■	■	■			■			■
ELSR-N-BO	■	■	■			■			■
ELSR-N-BOT	■	■	■	■		■			■
ELSR-LS-AO	■	■	■			■			■
ELSR-LS-BO	■	■	■			■			■
ELSR-M-AO	■	■	■			■			■
ELSR-M-BO	■	■	■			■			■
ELSR-M-AF/BF	■	■			■	■			
ELSR-R-BOT	■	■	■	■		■			
ELSR-W-AO	■	■	■				■		
ELSR-W-BO	■	■	■				■		
ELSR-H-BOT	■	■	■	■				■	■
ELSR-Ramp	■	■	■				■		
ELSR-FHP	■	■	■	■			■		■

You can directly select the heating cable for your special application from this table. Technical details on the products are given in the respective data sheets.

Production at eltherm

The matrix is the most important quality aspect for self-regulating heating cables. In order to be able to exercise the greatest possible influence on this production process, we manufacture the granulate for the matrix ourselves. As a result of this, eltherm is one of the top manufacturers of self-regulating heating cables in the world. This is also influenced by the special pre-treatment of the components and our long-time experience with these parameters. We are therefore able to guarantee constant high quality.



Applications

There are many applications where electrical heat tracing systems are needed for.



Typical Applications are e.g.:

Frost Protection and Temperature Maintenance for

- Chemical and petrochemical industry
- Power plants
- Oil and gas industry
- Tank bottom heating at LNG storage tanks
- Pipes in industrial and building construction applications
- Tank containers, IBC's
- Drums
- Pumps, valves
- Food industry
- Paper industry
- Automotive industry
- Gluing roboters
- Bitumen applications
- Gas analysis
- Particle accelerator
- Potable and waste water
- Antennas
- Sugar silos
- Colours and paints
- Coating technology
- Offshore applications
- Rail and point heating
- many more

ELSR

Application Options

The application options for the ELSR heating cables range from frost protection to temperature maintenance on pipes and vessels. In addition to our classic ELSR-N, we offer further low-temperature range versions: the narrower LS and M variants as well as the round heating cable ELSR-R.

In the medium-temperature range, we can supply the ELSR-W and we have the high temperature cable ELSR-H for temperatures up to 210° C.

Matching accessories round out our program: connection and termination kits, mounting material and you can find plenty more in the extensive technical data sheets related hereto.

All eltherm heating cables are approved by the VDE (German Association for Electrical, Electronic and Information Technologies). Moreover, selected ELSR heating cables are also **Ex-approved** and therefore approved for use in hazardous areas.

Design: 4 different options

We offer a wide selection of self-regulating heating cable designs, capable of handling every application, including service in harsh conditions and corrosive environments.

AO: Aluminum foil with a thermoplastic outer jacket

The heating cables with this design are particularly easy to assemble. This design is available for all low-temperature and medium-temperature tapes.

BO: Protective braid with a thermoplastic outer jacket

This proven design provides a protective tin-plated copper braid. The BO design is available for all low and medium temperature tapes.

BOT: Protective braid with fluoropolymer outer jacket

This outer jacket made of fluoropolymer material makes the heating cable extremely robust: it even withstands aggressive chemicals, oil and fuel. You find a detailed list of the resistance to chemicals on our homepage. This outer jacket is available for various ELSR-heating cables.

BF: Protective braid with food approved outer jacket, approved for use in potable water

A heating cable of this design can be used directly inside potable water lines. This design is currently only available for the ELSR-M version.

We also offer heating cables with braid only, without outer jacket, upon request.

Heating Cable

Self-regulating



The versatile self-regulating heating cable ELSR-N is suited for frost protection and temperature maintenance in the low temperature range of industrial applications. Likewise it is approved for use in hazardous areas. The BOT version of this heating cable even withstands aggressive chemicals, oil and fuel and, thanks to this high chemical resistance, stands out for a long lifetime.

Advantages:

- Self-regulating
- Four nominal outputs
- Can be cut to length off the roll
- Moisture proof
- UV-resistant
- Approved for use in hazardous areas

Applications:

- Frost protection
- Heat tracing on level indicators
- Chemical & petrochemical industries
- Tank bottom heating of LNG storage tanks
- Pipe heat tracing
- Vessels and tanks
- Automotive
- Food processing industry



Type ELSR-N up to 80 °C

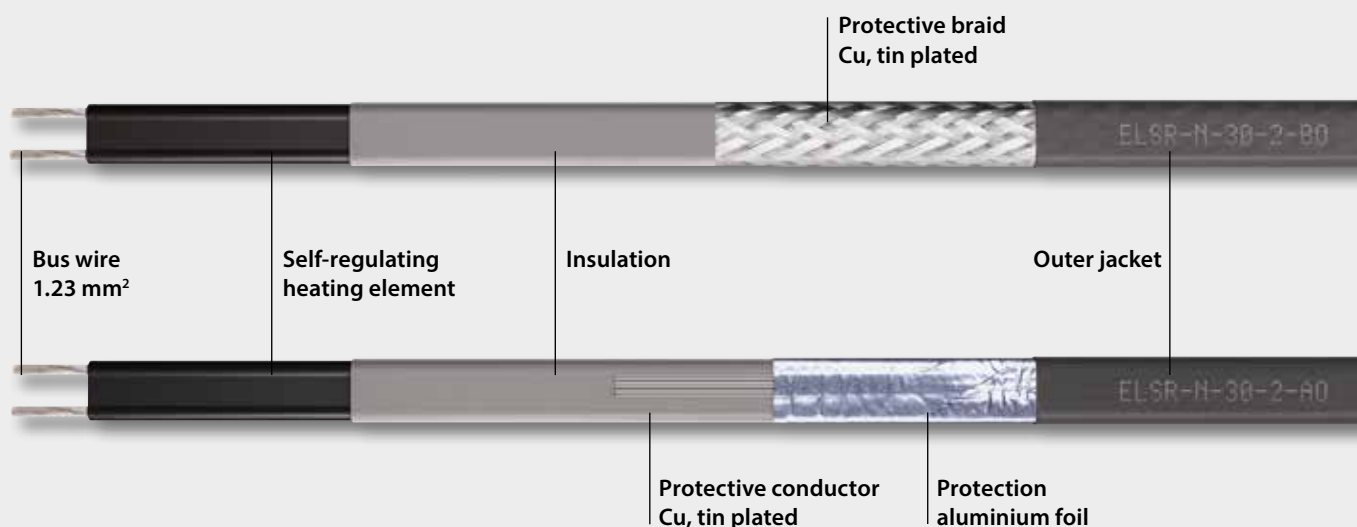



Technical Information

Type ELSR-N up to 80 °C

Data

■ Outer jacket	TPE-O
■ Bus wire	Nickel plated copper
■ Maximum exposure temperature (power off)	80 °C
■ Maximum exposure temperature (power on)	65 °C
■ Nominal voltage	230 V
■ Bending radius, min.	25 mm
■ Installation temperature, min.	-45 °C
■ Classification system	IBExU II 2G Ex e IIC T6 Gb II 2D Ex tb IIIC TX Db
■ Classification cable	EPS II 2G Ex e IIC Gb II 2D Ex tb IIIC Db
■ Certificates	12ATEX1431U IECEX EPS 12.0006U

Design

■ BO	Protective braid and a thermoplastic outer jacket
■ AO	Aluminium foil and a thermoplastic outer jacket
■ BOT	Protective braid and a fluoropolymer outer jacket

Heating circuit lengths ELSR-N-...-2 on the following conditions:

- 230 V nominal voltage
- Delayed action circuit breakers (C-characteristic) with 80 % maximum load
- Maximum 10 % line voltage drop on the heating cable bus wire
- Power connection to one (1) heater end

ELSR-N-...-2 output

(on insulated metallic pipes in accordance with EN 62395-1)

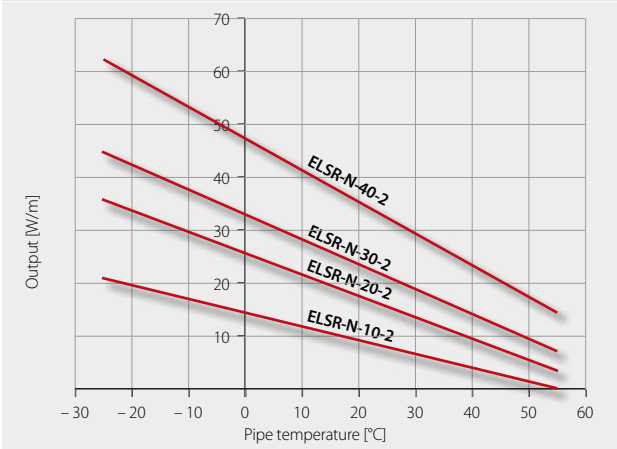

Switch-on temperature	Nominal cutout value (A)	Heating circuit length (m) for			
		ELSR-N-10-2	ELSR-N-20-2	ELSR-N-30-2	ELSR-N-40-2
10	10	128	68	52	36
	16	177	109	83	57
	20	177	129	104	71
	25	177	129	113	89
	32	177	129	113	94
0	10	106	57	45	31
	16	160	92	71	50
	20	160	115	89	62
	25	160	119	105	78
	32	160	119	105	88
-10	10	90	50	39	28
	16	144	79	63	44
	20	149	99	78	55
	25	149	111	98	69
	32	149	111	98	83
-20	10	78	44	35	25
	16	125	70	56	40
	20	139	87	69	50
	25	139	104	87	62
	32	139	104	87	78
-40	10	62	35	28	21
	16	99	56	45	33
	20	124	71	57	42
	25	124	88	71	52
	32	124	88	71	66

Type	Nominal output	Dimensions approx. (mm)	Weight approx. (g/m)	Art. No.
ELSR-N-10-2-AO	10 W/m at 10 °C	13.6 x 5.5	91	B0200130
ELSR-N-10-2-BO	10 W/m at 10 °C	14.1 x 5.8	108	B0200110
ELSR-N-10-2-BOT	10 W/m at 10 °C	13.8 x 5.6	108	B0200119
ELSR-N-20-2-AO	20 W/m at 10 °C	13.6 x 5.5	91	B0200230
ELSR-N-20-2-BO	20 W/m at 10 °C	14.1 x 5.8	108	B0200210
ELSR-N-20-2-BOT	20 W/m at 10 °C	13.8 x 5.6	108	B0200219
ELSR-N-30-2-AO	30 W/m at 10 °C	13.6 x 5.5	91	B0200330
ELSR-N-30-2-BO	30 W/m at 10 °C	14.1 x 5.8	108	B0200310
ELSR-N-30-2-BOT	30 W/m at 10 °C	13.8 x 5.6	108	B0200319
ELSR-N-40-2-AO	40 W/m at 10 °C	13.6 x 5.5	91	B0200430
ELSR-N-40-2-BO	40 W/m at 10 °C	14.1 x 5.8	108	B0200410
ELSR-N-40-2-BOT	40 W/m at 10 °C	13.8 x 5.6	108	B0200419

Heating Cable Light 'Super' Self-regulating



The versatile self-regulating heating cable ELSR-LS is our 'light' version for temperatures up to 80 °C. This heating cable is also suited and approved for use in hazardous areas. Since eltherm® self-regulating cables can be cut off the roll to the desired length, the application cable is highly flexible to match our customer's needs. Its long life span guarantees for the efficient use in many industrial sectors.

Advantages:

- Self-regulating
- Four nominal outputs
- Can be cut to length off the roll
- Moisture proof
- UV-resistant
- Small dimensions

Applications:

- Pipe heat tracing
- Frost protection for industrial applications
- Temperature maintenance for pipes and vessels
- Chemical & petrochemical industries
- Paints & varnishes
- Automotive
- Food processing industry



Type ELSR- LS up to 80 °C

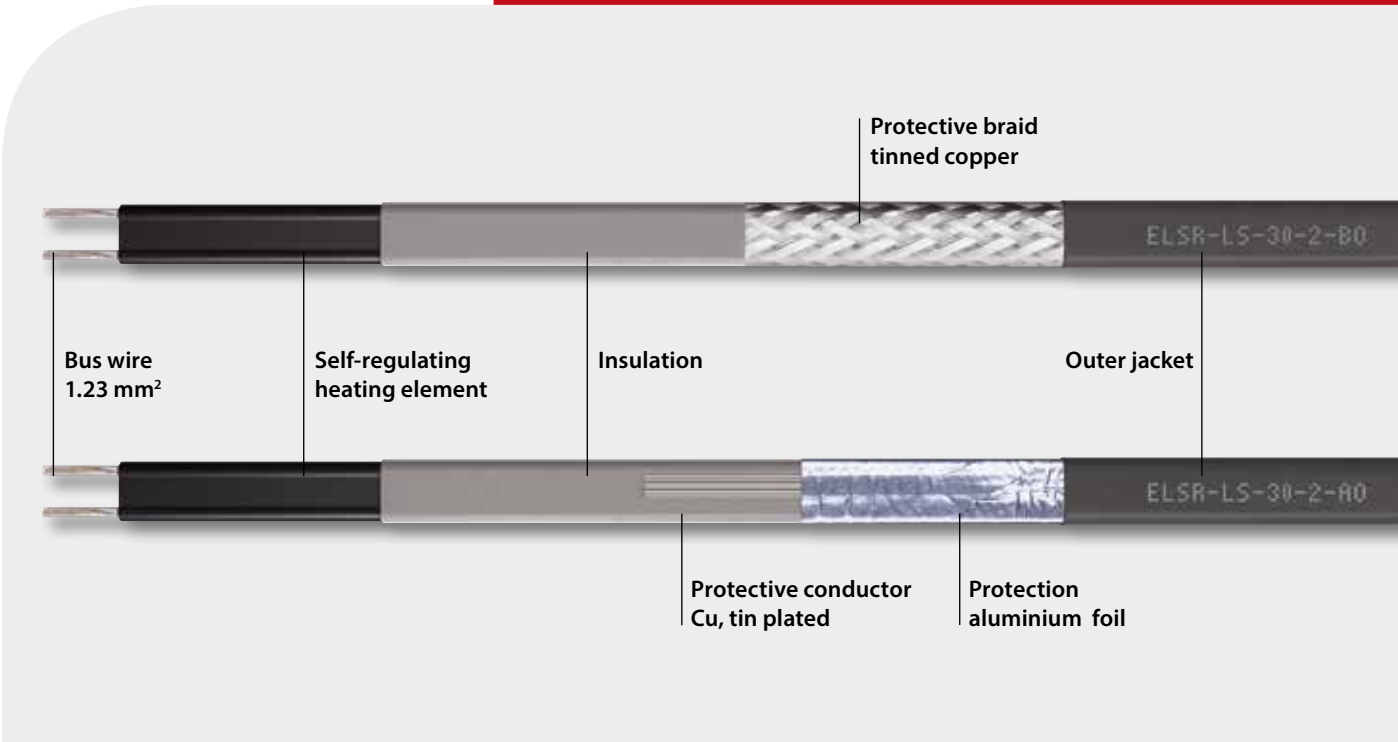

Technical Information

Type ELSR- LS up to 80 °C

Data

■ Outer jacket	TPE-O
■ Bus wire	1,23 mm ² nickel plated copper
■ Maximum exposure temperature (power off)	80 °C
■ Maximum exposure temperature (power on)	65 °C
■ Nominal voltage	230 V
■ Bending radius, min.	25 mm
■ Installation temperature, min.	- 50 °C
■ Classification system	IBExU II 2G Ex e IIC T6 Gb II 2D Ex tb IIIC TX Db
■ Classification cable	EPS II 2G Ex e IIC Gb II 2D Ex tb IIIC Db
■ Certificates	12ATEX1431U IECEX EPS 12.0006U

Design

- BO Protective braid and a thermoplastic outer jacket
- AO Aluminium foil and a thermoplastic outer jacket

Heating circuit lengths ELSR- LS -...-2 on the following conditions

- 230 V nominal voltage
- Delayed action circuit breakers (C-characteristic) with 80 % maximum load
- Maximum 10 % line voltage drop on the heating cable bus wire
- Power connection to one (1) heater end

ELSR-LS-...-2 output

(on insulated metallic pipes in accordance with EN 62395-1)

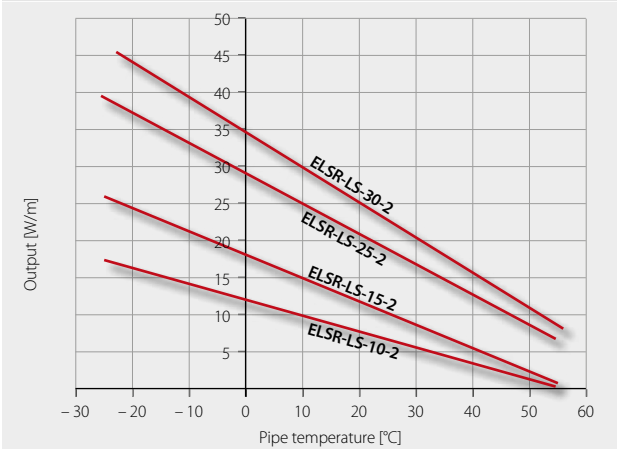

Switch-on temperature (°C)	Nominal cutout value (A)	Heating circuit length (m) for			
		ELSR-LS-10-2	ELSR-LS-15-2	ELSR-LS-25-2	ELSR-LS-30-2
10	10	152.0	103.0	64.0	49.0
	16	196.0	160.5	103.0	78.0
	20	196.0	160.5	126.0	97.5
	25	196.0	160.5	126.0	112.5
0	10	141.0	84.0	54.0	44.0
	16	188.5	134.0	87.0	70.0
	20	188.5	145.0	108.0	87.5
	25	188.5	145.0	116.0	104.0
-10	10	119.0	71.0	47.0	38.0
	16	173.5	114.0	75.0	61.0
	20	173.5	133.0	94.0	76.0
	25	173.5	133.0	107.5	95.0
-20	10	103.0	62.0	37.5	33.0
	16	161.0	99.0	60.0	53.0
	20	161.0	124.0	75.0	66.0
	25	161.0	124.0	94.0	83.0

Type	Nominal output	Dimensions approx. (mm)	Weight approx. (g/m)	Art. No.
ELSR-LS-10-2-AO	10 W/m at 10 °C	10.3 x 5.5	78	B0223104
ELSR-LS-10-2-BO	10 W/m at 10 °C	10.8 x 5.6	98	B0223102
ELSR-LS-15-2-AO	15 W/m at 10 °C	10.3 x 5.5	78	B0223154
ELSR-LS-15-2-BO	15 W/m at 10 °C	10.8 x 5.6	98	B0223152
ELSR-LS-25-2-AO	25 W/m at 10 °C	10.3 x 5.5	78	B0223254
ELSR-LS-25-2-BO	25 W/m at 10 °C	10.8 x 5.6	98	B0223252
ELSR-LS-30-2-AO	30 W/m at 10 °C	10.3 x 5.5	78	B0223304
ELSR-LS-30-2-BO	30 W/m at 10 °C	10.8 x 5.6	98	B0223302

Heating Cable Micro

Self-regulating

The heating cable ELSR-M is very flexible and is used for special applications where installation dimensions are needed to be kept small. It is particularly suited for short heating circuits. This heating cable can be used for frost protection and temperature maintenance up to 65 °C.

Advantages:

- Self-regulating
- Two nominal outputs
- Can be cut to length off the roll
- Moisture proof
- UV-resistant
- Small dimensions

Applications:

- Heat tracing on pipes, pumps and valves
- Food processing industry
- Automotive
- Heating of tube bundle cables for water analysis
- Heat tracing on vessels



Type **ELSR-M** up to 65 °C

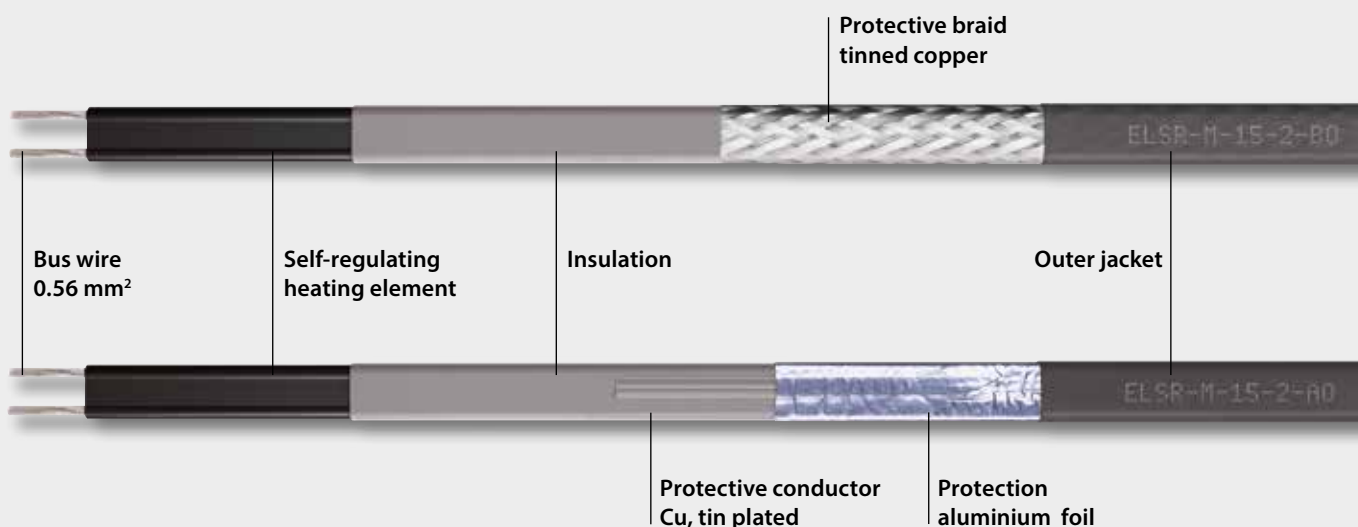



Technical Information

Type ELSR-M up to 65 °C

Data

■ Outer jacket	TPE-O
■ Bus wire	Nickel plated copper
■ Maximum exposure temperature (power off)	65 °C
■ Maximum exposure temperature (power on)	65 °C
■ Nominal voltage	230 V
■ Bending radius, min.	25 mm
■ Installation temperature, min.	-45 °C

Design

■ BO	Protective braid and a thermoplastic outer jacket
■ AO	Aluminium foil and a thermoplastic outer jacket

Heating circuit lengths ELSR-M-...-2:

- 230 V nominal voltage
- Delayed action circuit breakers (C-characteristic) with 80 % maximum load
- Maximum 10 % line voltage drop on the heating cable bus wire
- Power connection to one (1) heater end

ELSR-M-...-2 output

(on insulated metallic pipes in accordance with EN 62395-1)

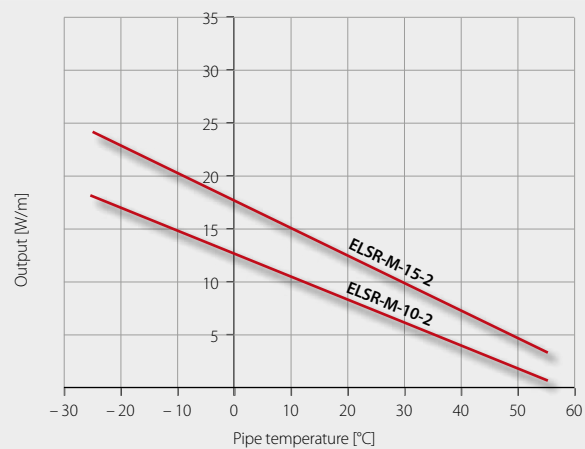

Switch-on temperature	Nominal cutout value (A)	Heating circuit length (m) for	
		ELSR-M-10-2	ELSR-M-15-2
10	10	126.5	98.0
	16	126.5	105.5
	20	126.5	105.5
0	10	115.5	83.0
	16	115.5	97.5
	20	115.5	97.5
-10	10	100.0	72.0
	16	106.5	91.0
	20	106.5	91.0
-20	10	87.0	64.0
	16	99.5	85.5
	20	99.5	85.5
-40	10	69.0	52.0
	16	88.5	77.0
	20	88.5	77.0

Type	Nominal output	Dimensions approx. (mm)	Weight approx. (g/m)	Art. No.
ELSR-M-10-2-AO	10 W/m at 10 °C	8.0 x 5.5	53	B0225110
ELSR-M-10-2-BO	10 W/m at 10 °C	8.5 x 5.8	62	B0225102
ELSR-M-15-2-AO	15 W/m at 10 °C	8.0 x 5.5	53	B0225160
ELSR-M-15-2-BO	15 W/m at 10 °C	8.5 x 5.8	62	B0225152

Heating Cable Micro

approved for use in Potable Water

ELSR-M-AF/BF is the light construction of a self-regulating heating cable featuring an outer jacket which is food-safe and approved for use in potable water. A typical application area is frost protection of potable water lines. Likewise it is suited to maintain temperatures, for instance in the food processing industry. The heating cable ELSR-M-AF/BF provides smallest dimensions and is highly flexible with special applications. It perfectly suits short heating circuits. Unlike other self-regulating heating cables, the ELSR-M-AF/BF can be installed **inside** a pipeline.

Advantages:

- KTW-approved, DVGW-approved
- Can be cut to length off the roll
- Moisture proof
- Small dimensions

Application:

- Internal trace heating for pipes and hoses



Type **ELSR-M-AF/BF** up to 65°C

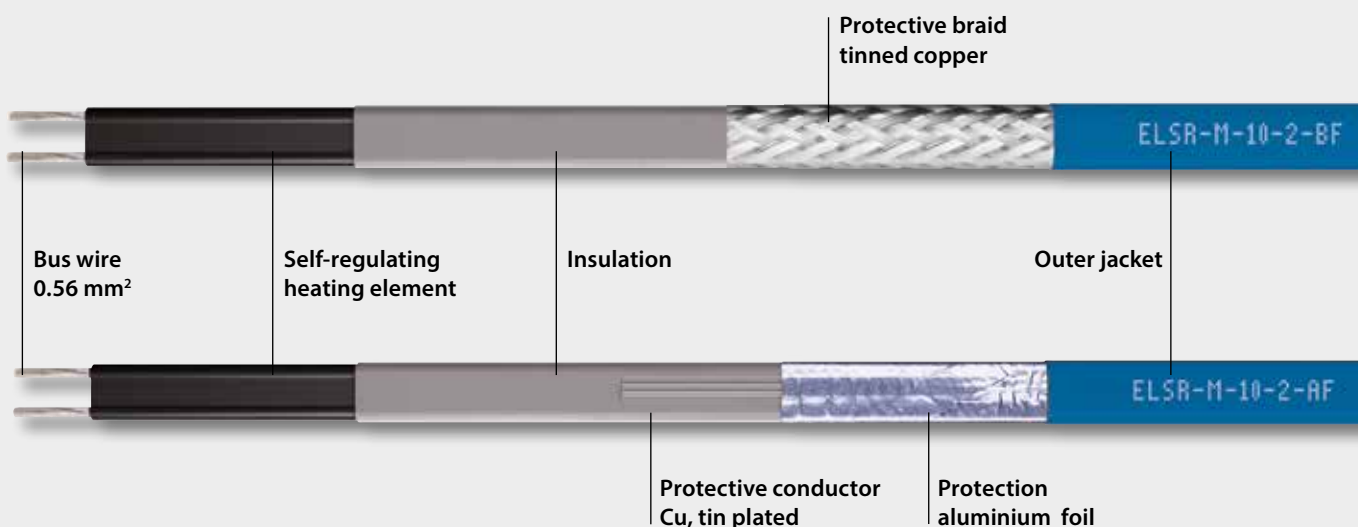



Technical Information

Type ELSR-M-AF/BF up to 65 °C

Data

■ Outer jacket	Polyethylene
■ Bus wire	Nickel plated copper
■ Maximum exposure temperature (power off)	65 °C
■ Maximum exposure temperature (power on)	65 °C
■ Nominal voltage	230 V
■ Bending radius, min.	25 mm
■ Installation temperature, min.	-45 °C
■ Certificate	K-229437-13-Bs/st

Design

- BF Protective braid and food-safe outer jacket, suited for use in potable water (tested by the Hygiene Institut des Ruhrgebiets [Hygienic Institute of the 'Ruhr area'])
- AF Aluminium foil and food-safe outer jacket, for use in potable water (tested by the Hygiene Institut des Ruhrgebiets [Hygienic Institute of the 'Ruhr area'])

Heating circuit lengths ELSR-M-10-2-BF/AF on the following conditions:

- 230 V nominal voltage
- Delayed action circuit breakers (C-characteristic) with 80 % maximum load
- Maximum 10 % line voltage drop on the heating cable bus wire
- Power connection to one (1) heater end

ELSR-M-10-2-BF / AF output

(in a filled water pipeline)

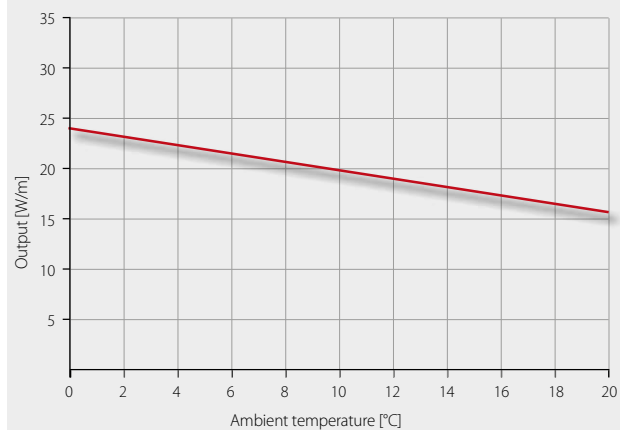

Switch-on temperature	Nominal cutout value (A)	Heating circuit length (m) for
		ELSR-M-10-2-BF / AF
10	10	74.0
	16	89.5
	20	89.5
0	10	61.5
	16	89.5
	20	89.5
-30	10	61.5
	16	89.5
	20	89.5

Type	Nominal output	Dimensions approx. (mm)	Weight approx. (g/m)	Art. No.
ELSR-M-10-2-BF	10 W/m at 10 °C	7.5 x 4.9	62	B0225104
ELSR-M-10-2-AF	10 W/m at 10 °C	7.0 x 4.6	53	B0225105

Heating Cable Round

Self-regulating

The 'R' in the name of our self-regulating heating cable ELSR-R is an abbreviation for 'round'. This heating cable was specially developed to protect the doors and seals of refrigerating chambers against frost as well as for all applications requiring a round heating cable.

It is also often used in cooling water lines of breweries and drinks manufacturers (as frost protection). The maximum exposure temperature is 65 °C.

Advantages:

- Round design
- Self-regulating
- Can be cut to length off the roll
- Moisture proof
- UV-resistant
- Perfectly suited for installation with sections thanks to round shape

Applications:

- Frost protection for doors and seals of refrigerating chambers
- Usage in cooling water lines of breweries and drink manufacturers



Type ELSR-R up to 65 °C

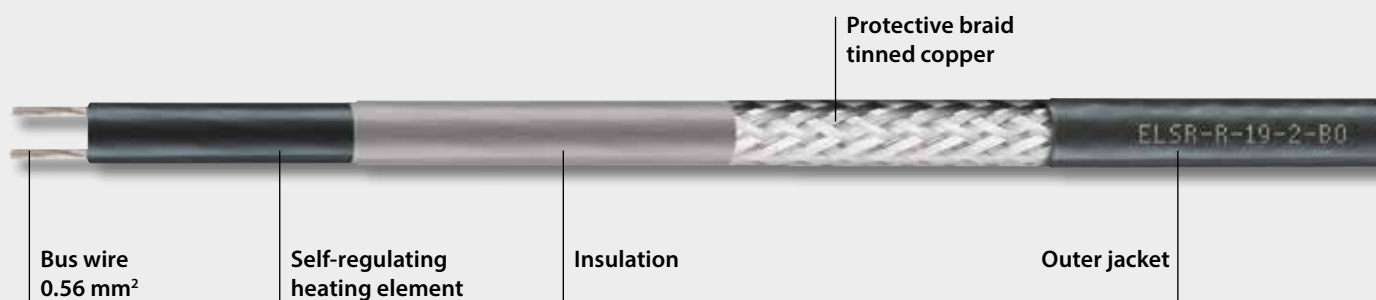



Technical Information

Type ELSR-R up to 65 °C

Data

■ Outer jacket	Fluoropolymer
■ Bus wire	Nickel plated copper
■ Maximum exposure temperature (power off)	65 °C
■ Maximum exposure temperature (power on)	65 °C
■ Nominal voltage	230 V
■ Bending radius, min.	30 mm
■ Installation temperature, min.	- 30 °C

Design

- BOT Protective braid and a fluoropolymer outer jacket

Heating circuit lengths ELSR-R...-2-BOT on the following conditions:

- 230 V nominal voltage
- Delayed action circuit breakers (C-characteristic) with 80 % maximum load
- Maximum 10 % line voltage drop on the heating cable bus wire
- Power connection to one (1) heater end

ELSR-R...-2-BOT output

(on insulated metallic pipes in accordance with EN 62395-1)

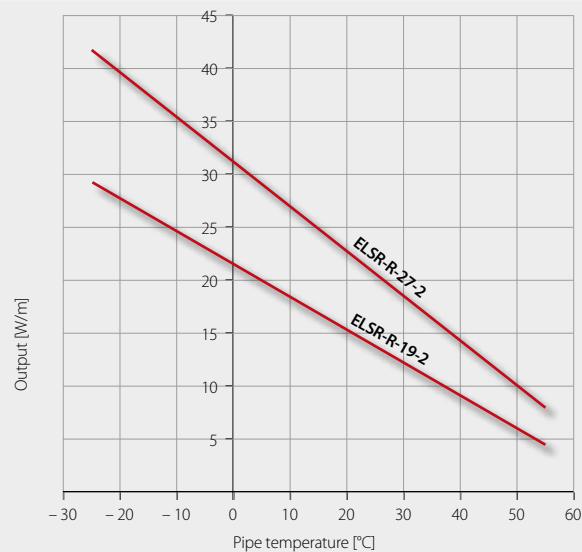

Switch-on temperature	Nominal cutout value (A)	Heating circuit length (m) for	
		ELSR-R-19-2	ELSR-R-27-2
10	10	75.0	20.0
	16	102.0	32.0
	20	102.0	40.0
0	10	62.0	16.5
	16	94.0	26.5
	20	94.0	33.0
-10	10	51.0	13.5
	16	81.5	21.5
	20	88.0	27.0
-20	10	41.0	11.0
	16	65.5	17.5
	20	82.0	22.0
-40	10	30.0	7.5
	16	48.0	12.0
	20	60.0	15.0

Type	Nominal output	Dimensions approx. (mm)	Weight approx. (g/m)	Art. No.
ELSR-R-19-2-BOT	19 W/m at 10 °C	7.3	77	B0200507
ELSR-R-27-2-BOT	27 W/m at 10 °C	7.3	74	B0200605

Other versions are available upon request.

This heating cable has specially been developed for the use with doors of refrigerating chambers. Please contact our engineers for more details on our ELSR-R.

Heating Cable Hot Water Self-regulating

The self-regulating heating cable ELSR-W (hot water) is used for vessels, pipes, valves and several other applications with processing temperatures between 30 °C and 80 °C approximately (power on) and 100°C (power off). The ELSR-W self-regulating heating cables are frequently used to heat oil and fat lines, for example in the food processing industry. But likewise its use for drainage lines in canteens and (large scale) kitchens makes good sense, avoiding fat and oil deposits by heating. Used for hot water supplies, it serves for frost protection, temperature maintenance and prevention of Legionella formation.

Advantages:

- Self-regulating
- Two nominal outputs
- Can be cut to length off the roll
- Moisture proof

Applications:

- Food processing industry
- Heat tracing on fat lines
- Drainage lines in canteens and large-scale kitchens
- Frost protection for heating lines
- Installation on hot water supplies to prevent Legionella formation



Type ELSR-W up to 100 °C

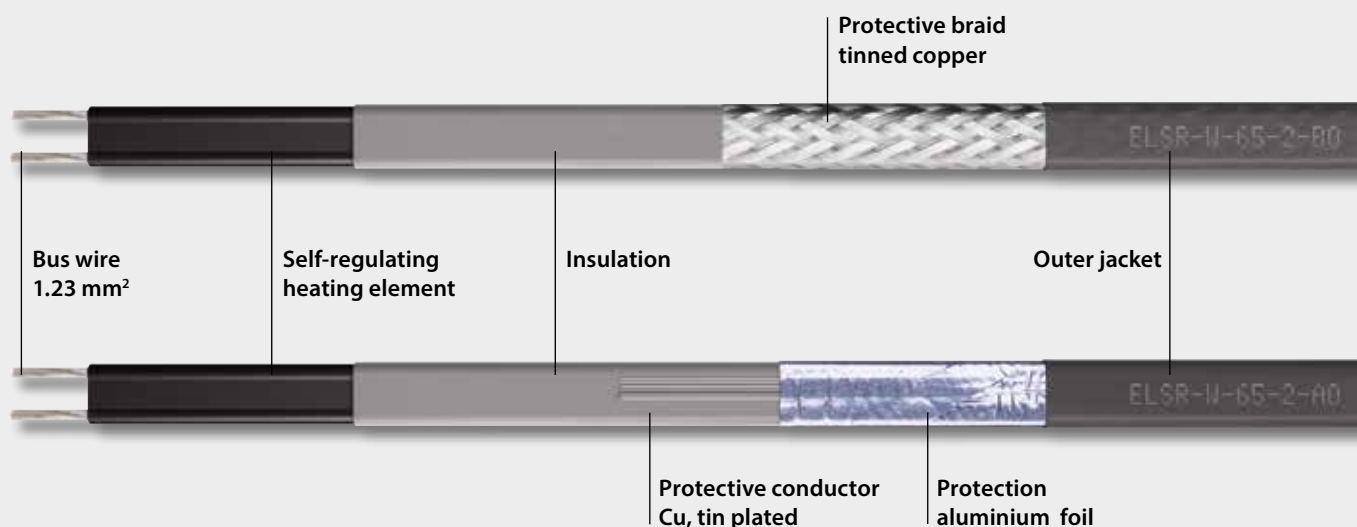

Technical Information

Type ELSR-W up to 100 °C

Data

■ Outer jacket	TPE-O
■ Bus wire	Nickel plated copper
■ Maximum exposure temperature (power off)	100 °C
■ Maximum exposure temperature (power on)	80 °C
■ Nominal voltage	230 V
■ Bending radius, min.	20 mm
■ Installation temperature, min.	-20 °C

Design

■ BO	Protective braid and a thermoplastic outer jacket
■ AO	Aluminium foil and a thermoplastic outer jacket

Heating circuit lengths ELSR-W-...-2-... on the following conditions:

- 230 V nominal voltage
- Delayed action circuit breakers (C-characteristic) with 80 % maximum load
- Maximum 10 % line voltage drop on the heating cable bus wire
- Power connection to one (1) heater end

ELSR-W-...-2-... output

(on insulated metallic pipes in accordance with EN 62395-1)

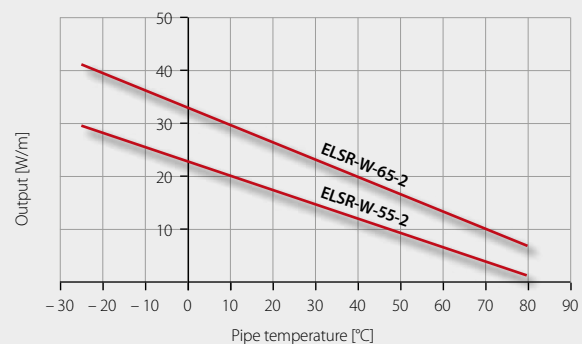

Switch-on temperature	Nominal cutout value (A)	Heating circuit length (m) for	
		ELSR-W-55-2	ELSR-W-65-2
10	10	70.0	45.5
	16	113.0	73.5
	20	131.0	92.0
	25	131.0	106.0
	32	131.0	106.0
0	10	63.0	41.5
	16	101.0	66.0
	20	123.5	83.0
	25	123.5	99.5
-10	10	57.0	37.5
	16	91.0	60.0
	20	113.5	75.0
	25	117.0	94.0
-20	10	52.0	34.0
	16	83.0	55.0
	20	104.0	69.5
	25	112.0	86.0
-40	10	44.0	29.5
	16	70.0	48.0
	20	88.0	59.0
	25	103.0	74.0
	32	103.0	83.5

Type	Nominal output used for water supply lines	Dimensions approx. (mm)	Weight approx. (g/m)	Art. No.
ELSR-W-55-2-AO	9 W/m at 55 °C	12.9 x 5.0	86	B0200360
ELSR-W-55-2-BO	9 W/m at 55 °C	12.9 x 5.0	105	B0200350
ELSR-W-65-2-AO	13 W/m at 65 °C	12.9 x 5.0	86	B0200455
ELSR-W-65-2-BO	13 W/m at 65 °C	12.9 x 5.0	105	B0200450

Type	Nominal output used with fat/ oil lines	Dimensions approx. (mm)	Weight approx. (g/m)	Art. No.
ELSR-W-65-2-AO	22 W/m at 40 °C	12.9 x 5.0	86	B0200455
ELSR-W-65-2-BO	22 W/m at 40 °C	12.9 x 5.0	105	B0200450

Heating Cable High Temperature, Self-regulating



The versatile self-regulating heating cable ELSR-H is for high temperatures up to 210 °C in a large number of industrial applications. It is also suited and approved for use in hazardous areas. The BOT version of this heating cable even withstands aggressive chemicals, oil and fuel and, thanks to this high chemical resistance, stands out for a long life span.

Advantages:

- Up to 120 °C/210 °C
- Self-regulating
- Six nominal outputs
- Can be cut to length off the roll
- Moisture proof
- Resistant to chemicals
- Approved for use in hazardous areas

Applications:

- Chemical & petrochemical industries
- Oil & gas industry
- Power plants
- Ex-areas
- Frost protection
- Water & sanitation utilities
- Temperature maintenance on vessels, pipes & valves



Type ELSR-H up to 210 °C

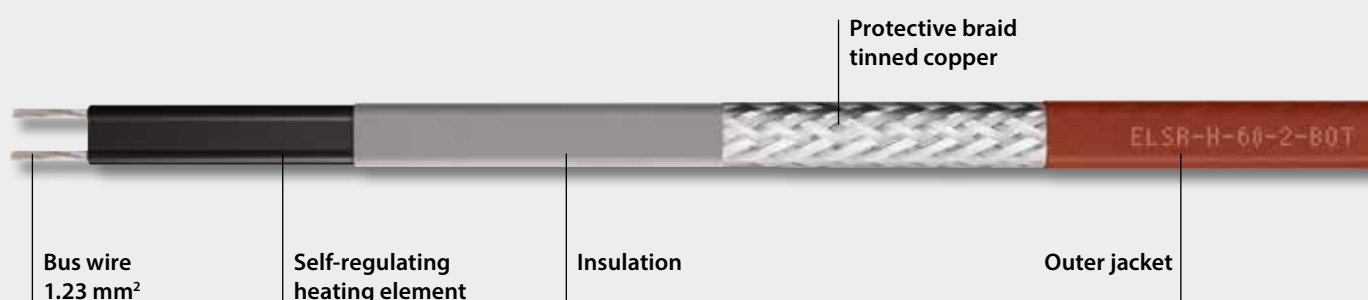



Technical Information

Type ELSR-H up to 210 °C

Data

■ Outer jacket	TPE-O Fluoropolymer
■ Bus wire	Nickel plated copper
■ Maximum exposure temperature (power off)	210 °C
■ Maximum exposure temperature (power on)	120 °C
■ Nominal voltage	230 V / (120 V, 277 V)*
■ Bending radius, min.	25 mm
■ Installation temperature, min.	-45 °C
■ Classification system	IBExU II 2G Ex e IIC T3 Gb II 2D Ex tb IIIC TX Db IBExU II 2G Ex e IIC T4...T6 Gb II 2D Ex tb IIIC TX Db (stabilized design)
■ Classification cable	EPS II 2G Ex e IIC Gb II 2D Ex tb IIIC Db
■ Certificates	12ATEX1429U IECEX EPS 12.0004U

*upon request

Design

- BOT Protective braid and a fluoropolymer outer jacket

Heating circuit lengths ELSR-H-...-2-BOT on the following conditions:

- 230 V nominal voltage
- Delayed action circuit breakers (C-characteristic) with 80 % maximum load
- Maximum 10 % line voltage drop on the heating cable bus wire
- Power connection to one (1) heater end

ELSR-H-...-2-BOT output

(on insulated metallic pipes in accordance with EN 62395-1)

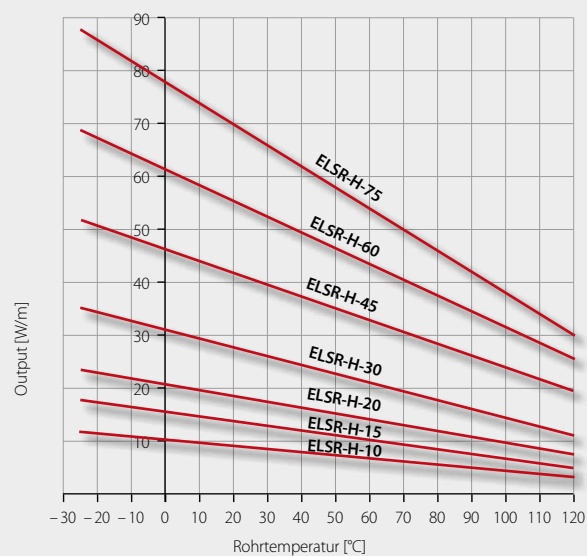

Switch-on temperature	Nominal cutout value (A)	Heating circuit length (m) for ELSR-H-						
		10-2	15-2	20-2	30-2	45-2	60-2	75-2
10	16	193.0	158.0	122.0	82.0	55.0	41.0	33.0
	20	193.0	158.0	136.0	102.0	68.0	51.0	41.5
	25	193.0	158.0	136.0	111.0	85.0	64.0	51.5
	32	193.0	158.0	136.0	111.0	91.0	79.0	66.0
0	16	189.0	153.0	116.0	77.0	52.0	39.0	30.0
	20	189.0	153.0	132.0	97.0	65.0	49.0	37.5
	25	189.0	153.0	132.0	108.0	81.0	61.0	47.0
	32	189.0	153.0	132.0	108.0	88.5	77.0	60.0
-10	16	184.0	146.0	110.0	73.0	50.0	37.0	28.5
	20	184.0	148.5	129.0	92.0	62.0	46.0	35.5
	25	184.0	148.5	129.0	105.5	77.0	58.0	44.5
	32	184.0	148.5	129.0	105.5	86.5	70.0	57.0
-20	16	180.0	139.0	104.0	70.0	47.0	36.0	26.5
	20	180.0	145.0	125.5	87.0	59.0	44.0	33.5
	25	180.0	145.0	125.5	103.0	74.0	56.0	41.5
	32	180.0	145.0	125.5	103.0	84.5	67.0	53.5
-40	16	173.0	126.0	95.0	64.0	43.0	33.0	23.5
	20	173.0	138.0	119.0	80.0	54.0	41.0	29.0
	25	173.0	138.0	120.0	98.0	68.0	51.0	36.5
	32	173.0	138.0	120.0	98.0	81.0	61.0	46.5

Type	Nominal output	Dimensions approx. (mm)	Weight approx. (g/m)	Art. No.
ELSR-H-10-2-BOT	10 W/m at 10 °C	12.4 x 5.0	120	B0221103
ELSR-H-15-2-BOT	15 W/m at 10 °C	12.4 x 5.0	120	B0221153
ELSR-H-20-2-BOT	20 W/m at 10 °C	12.4 x 5.0	120	B0221203
ELSR-H-30-2-BOT	30 W/m at 10 °C	12.4 x 5.0	120	B0221303
ELSR-H-45-2-BOT	45 W/m at 10 °C	12.4 x 5.0	120	B0221453
ELSR-H-60-2-BOT	60 W/m at 10 °C	12.4 x 5.0	120	B0221603
ELSR-H-75-2-BOT	75 W/m at 10 °C	12.4 x 5.0	120	B0221753

Concrete and Ramp Heating Cable

for Open Space and Ramp Heating

This heating cable is designed for easy and safe installation of open-space heaters. Accidents due to frost and snow are prevented all over the heated space. To ensure a high mechanical load capacity in open space, the eltherm engineers developed this heating cable especially robust. Suited for installation in sand/cement mixtures.

Advantages:

- Highly robust
- Suited for hardest installing conditions
- Flexible mounting
- Radially and longitudinally waterproof, outer jacket is strongly grouted with protective braid

Applications:

- Parking garages entrances and exits
- Helicopter landing sites
- Concrete ramps
- Stairs and footpaths



Type ELSR-Ramp

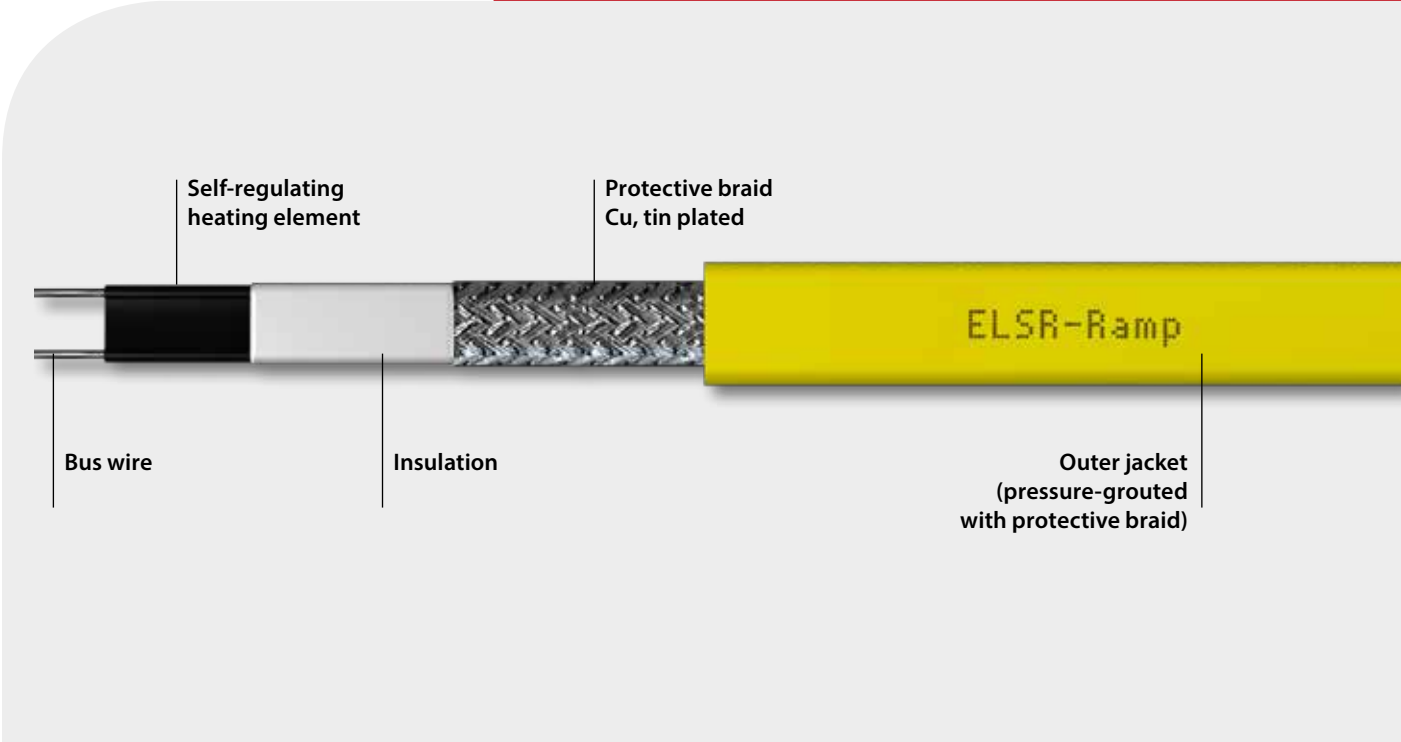



Technical Information

Type ELSR-Ramp

Data

■ Outer jacket	TPE
■ Bus wire	Nickel plated copper
■ Maximum exposure temperature (power off)	100 °C
■ Maximum exposure temperature (power on)	80 °C
■ Nominal voltage	230 V
■ Bending radius, min.	50 mm
■ Installation temperature, min.	- 20 °C
■ Nominal output	Approx. 50 W/m at 10 °C (110 W/m in concrete @ 5 °C)
■ Dimensions approx.	17.2 mm x 9.5 mm
■ Weight approx. (g/m)	253

Heating circuit lengths ELSR-Ramp on the following conditions:

- 230 V nominal voltage
- Delayed action circuit breakers (C-characteristic) with 80 % maximum load
- Maximum 10 % line voltage drop on the heating cable bus wire
- Power connection to one (1) heater end

Switch-on temperature	Nominal current value (A)	Heating circuit length (m) for
		ELSR-RAMP
-10	10	18
	16	28
	20	36
	25	45
	32	55

Type	Art. No.
ELSR-Ramp	B02RAMPO

* Heating circuit lengths may vary in specific installation situations. Please contact our engineers for more details.

Electrical protection

Maximum heating circuit length

- According to local standards and regulations.
- Take into account the conductor size and max. permitted voltage drop.
- A higher voltage drop can occur at start-up of heating.

Power at start-up

- To determine the installed power with the electrical system designer, the nominal current of the series connected fuse or the current value at the system start-up temperature must be taken into account (e.g. 32 A for 55 m ELSR-Ramp (-10°C).
- Residual current device (RCD) 30 mA required, max. 500 m heating cable per RCD.

Remark

- For the use of standard control cabinets, the maximum heating circuit length of 55 m at 32 A per heating circuit must not be exceeded.

Foundation Heating Cable

for Frost Heave Prevention



Freezing and frost heave may occur underneath the foundations of cooled storage areas. This can result in a deformation of the storage base and can cause severe structural damage to the foundation. The most effective way to prevent these effects from occurring is by means of electrical heating.

This specially designed heating cable prevents the foundation from freezing and frost formation by maintaining the temperature above freezing temperatures. A fluoropolymer outer jacket provides durability, good chemical compatibility and ease of installation. ELSR-FHP is suitable for use in hazardous areas.

Advantages:

- Highly robust
- Suitable for harsh installed environment
- Flexible mounting
- Waterproof

Applications:

- Frost Heave Prevention
- Cryogenic Storage Tanks



Type ELSR-FHP

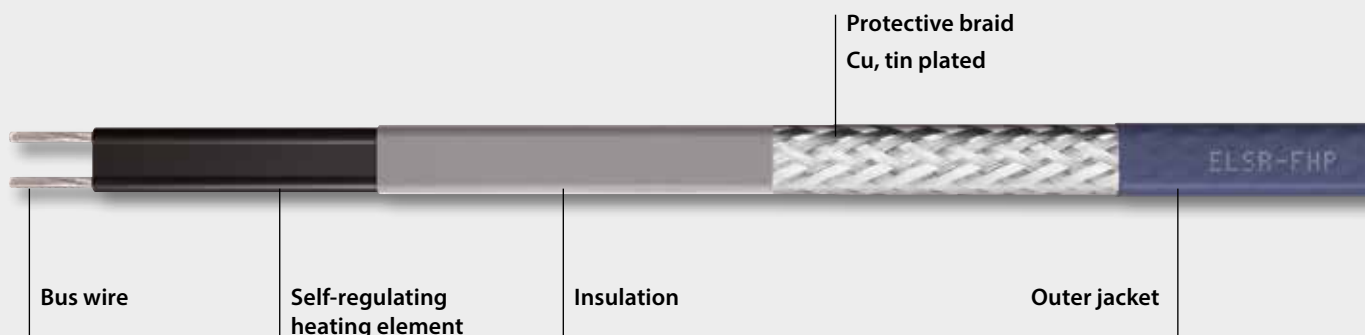



Technical Information

Type ELSR-FHP

Data

■ Outer jacket	Fluoropolymer
■ Bus wire	Nickel plated copper
■ Maximum exposure temperature (power off)	110 °C (ELSR-FHP-38) 80 °C (ELSR-FHP-23)
■ Maximum exposure temperature (power on)	80 °C (ELSR-FHP-38) 65 °C (ELSR-FHP-23)
■ Nominal voltage	230 V
■ Bending radius, min.	50 mm
■ Installation temperature, min.	-45 °C
■ Classification system	II 2G Ex e IIC Gb II 2D Ex tb IIIC Db
■ Certificates	14ATEX1653X IECEX EPS 14.0021U

Heating circuit lengths ELSR-FHP on the following conditions:

- 230 V nominal voltage
- Delayed action circuit breakers (C-characteristic) with 80 % maximum load
- Maximum 10 % line voltage drop on the heating cable bus wire
- Power connection to one (1) heater end, in 25 mm/1" conduit

ELSR-FHP-...-2 output

(in empty metallic protection pipes 1")

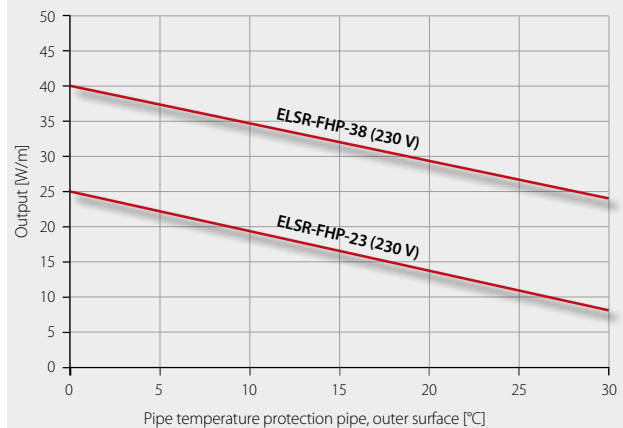

Switch-on temperature	Nominal cutout value (A) CB rating	Heating circuit length (m)* for	
		ELSR-FHP-23	ELSR-FHP-38
-5 °C	10	30	23
	16	48.5	36.5
	20	60.5	45.5
	25	75.5	57.5
	32	97	72.5
-15 °C	40	121	91.5
	10	23	21.5
	16	37	34.5
	20	46	43
	25	57.5	54
	32	74	68.5
	40	92	85.5

Type	Nominal output	Dimensions approx. (mm)	Weight approx. (g/m)	Art. No.
ELSR-FHP-23	approx. 23 W/m at 5 °C (in 25 mm / 1" conduit)	14 x 5.5	155	B02FHP23
ELSR-FHP-38	approx. 38 W/m at 5 °C (in 25mm/1" conduit)	14 x 5.5	155	B02FHP38

* Heating circuit lengths may vary in specific installation situations. Please contact our engineers for more details.

Technical Information

Type ELSR-FHP, operated at 277 VAC

Data

■ Outer jacket	Fluoropolymer
■ Bus wire	Nickel plated copper
■ Maximum exposure temperature (power off)	110 °C (ELSR-FHP-38) 80 °C (ELSR-FHP-23)
■ Maximum exposure temperature (power on)	80 °C (ELSR-FHP-38) 65 °C (ELSR-FHP-23)
■ Nominal voltage	230 V
■ Bending radius, min.	50 mm
■ Installation temperature, min.	- 45 °C
■ Classification system	II 2G Ex e IIC Gb II 2D Ex tb IIIC Db
■ Certificates	14ATEX1653X IECEx EPS 14.0021U

Heating circuit lengths ELSR-FHP on the following conditions:

- 230 V nominal voltage
- Delayed action circuit breakers (C-characteristic) with 80 % maximum load
- Maximum 10 % line voltage drop on the heating cable bus wire
- One (1) heating cable, powered from one end, in 25 mm/1" conduit

ELSR-FHP-...-2 output

(in empty metallic protection pipes 1")

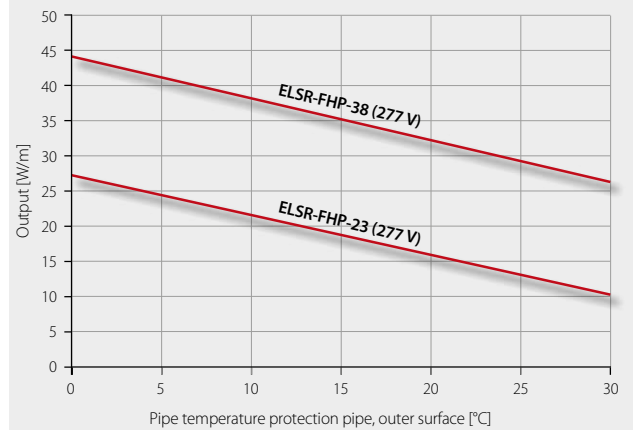

Switch-on temperature	Nominal cutout value (A) CB rating	Heating circuit length (m)* for	
		ELSR-FHP-23	ELSR-FHP-38
-5 °C	10	33	24.5
	16	55.5	39
	20	66	49
	25	83	62
	32	106	78
-15 °C	40	132	99
	10	25	23
	16	41	37
	20	50	46
	25	62.5	58
	32	81	74
	40	100	92

Type	Nominal output	Dimensions approx. (mm)	Weight approx. (g/m)	Art. No.
ELSR-FHP-23	approx. 25 W/m at 5 °C (in 25 mm/1" conduit)	14 x 5.5	155	B02FHP1
ELSR-FHP-38	approx. 42 W/m at 5 °C (in 25 mm/1" conduit)	14 x 5.5	155	B02FHP2

* Heating circuit lengths may vary in specific installation situations. Please contact our engineers for more details.

Cryogenic Storage Tank

Foundation Heating

The heat tracing engineers at eltherm have many years of experience developing the most efficient heating system designs in hundreds of applications, including gas processing, LNG and other cryogenic tank base heating.

Foundation Heating of Cryogenic Storage Tanks:

- Liquefaction at -162°C
- Frost heave prevention at the tank bottom

The eltherm heating system offers a reliable and effective operation, due to a redundant system. This configuration avoids a complete system failure and minimizes the risk of damage to the tank structure.

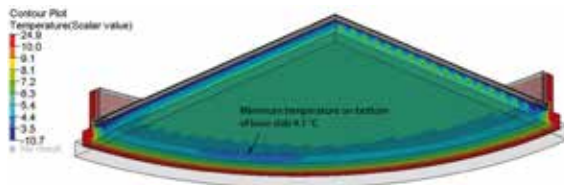
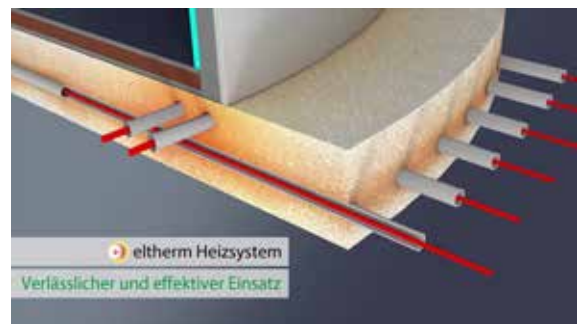

3-dimensional FEA tank base model showing temperature levels

Cryogenic storage/LNG tank foundations (a.k.a. the tank base) require heating systems which effectively allow heat to flow from the foundation upward creating a barrier to protect the base and underlying soil from freezing. The electrical heating elements are usually arranged in an array of parallel conduits in a horizontal plane with careful pitch-to-pitch calculation and simulation with ANSYS Finite Element Analysis (FEA) software.

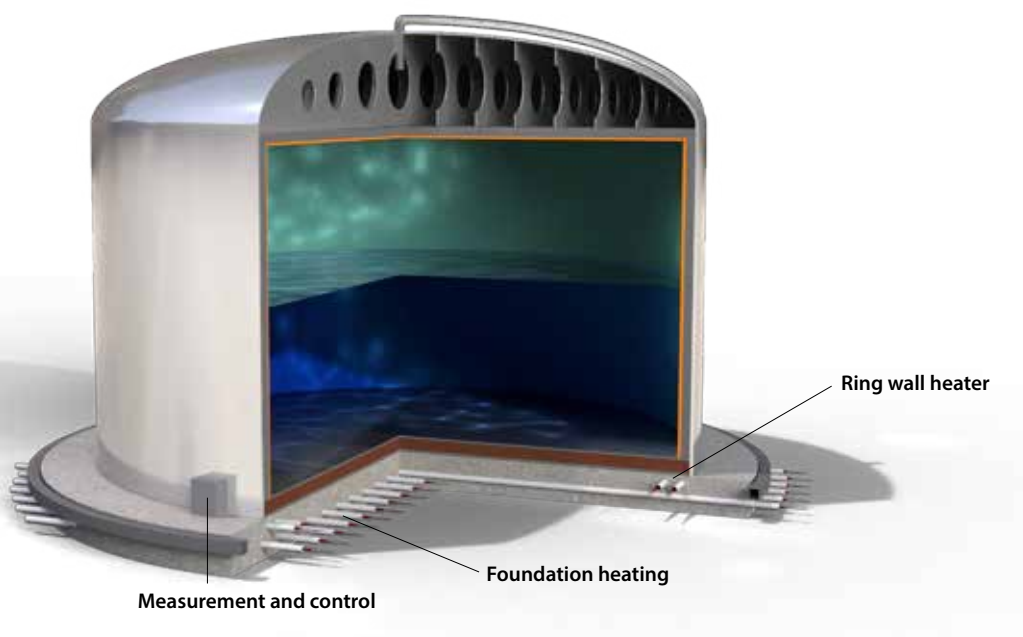

Schematic overview of a cryogenic tank base heating system

Electronic

Frost Protection Thermostat

The electronic temperature controller ELTC 05-Frostcontrol is designed for use as an ambient thermostat and surface thermostat with remote sensor. Cable glands and terminals are provided for power input. The unit is supplied in a weather proof plastic enclosure for wall mounting, with a grey cover.

The controller should be protected from direct sunlight when used outdoors. In case of use as ambient temperature controller, the sensor cable is shortened to allow fastening of the sensor sleeve within the M12 gland. The sleeve should project by approximately 15 mm.

Advantages:

- Weather proof
- Fixed switching set point

Applications:

- Heat tracing for frost protection
- Can be used as ambient and surface thermostat
- Suitable for resistance heating lines and self-regulating heating cables

Technical Information

Data

■ Supply voltage	230 V, +/- 10 %, 50 Hz, optional voltages upon request
■ Switching capacity	16 A
■ Hysteresis	Approx. 1 Kelvin
■ Measurement input	Pt100 DIN 2-wire, with 5 m PVC connecting cable (temp. max. 90 °C)
■ Switching point ELTC/05	+3 °C (set point)
■ Ambient temperature	-30 up to +60 °C
■ Control characteristics	Dual mode controller
■ Output	1 relay contact
■ LED	Heating ON (yellow)
■ Enclosure	Polycarbonate
■ Dimensions	130 x 130 x 75mm
■ IP rating	IP 65
■ Weight	520 g

Electronic Temperature Controller

- Type ELTC 05 Frostcontrol, switching point +3 °C (set point)

Function

If the sensed temperature is lower than the adjusted set point, the relay contact closes and the heating switches on.

Special designs available – just ask us!

Wiring diagram

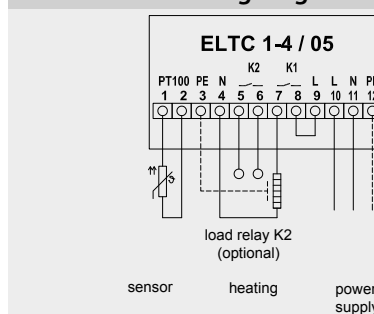

Type ELTC 05–Frostcontrol



Type	Designation	Art. No.
ELTC 05	Incl. Pt100, with 1 Relay, 230 V, 2xM25, 1xM12	0610002
ELTC 05	Incl. Pt100, with 1 Relay, 110 V, 2xM25, 1xM12	0610003
ELTC 05	Incl. Pt100, with 2 Relay, 230 V, 2xM25, 1xM12	0610005
ELTC 05	Without Pt100, with 1 Relay, 230 V, 2xM25, 1xM12	0610092

Note: Versions for higher temperatures are available upon request.

Electronic Temperature Controller

The ELTC-14 is an electronic temperature controller with digital display for wall mounting. The temperature is measured by a Pt100 sensor, processed by the microcontroller and displayed. After having evaluated the actual and preset values, the appropriate output relays are switched, depending on the configuration.

Cable glands and terminals are provided for the power connection. The unit is supplied in a weather proof plastic enclosure, with a transparent cover.

Advantages:

- LED display operable down to -25 °C
- Programmable 0 °C up to +390 °C
- For switching 20 A resistive load with hybridrelay
- Signaling contact (configurable to operate either as alarm or release contact, potential-free)
- Suitable for Pt100 with 2 or 3 wires
- For connection of up to 2 heating cables
- Operating voltage: 90 - 260 VAC / 50/60 Hz

Applications:

- Industrial applications
- Mechanical, electrical and plumbing (MEP)

Technical Information

Data

■ Operating voltage	90-260 VAC 50/60 Hz
■ Power consumption	Max. 4 mA, < 5 W
■ Switching capacity relay 1	20 A with hybridrelay
■ Switching capacity relay 2	8 A, changover contact (alarm)
■ Operating temperature	-25 up to +55 °C
■ Storage temperature	-30 up to +60 °C
■ Display range	-50 up to +400 °C
■ Adjustable range	0 up to +390 °C, optional configuration
■ Sensor connection	Pt100 2-wire, 3-wire, optional configuration
■ Display	LED, red
■ IP rating	IP 65
■ Dimensions (w x h x d)	130 x 130 x 75 mm polycarbonate enclosure

Type ELTC-14

Wiring diagram

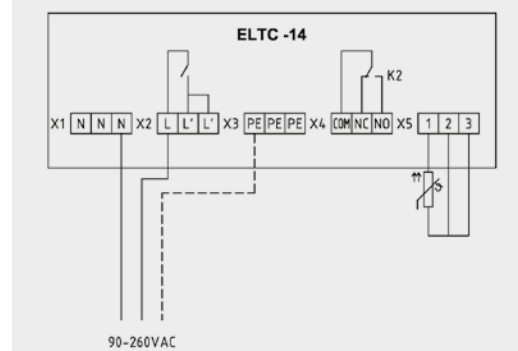

Sensors and display: It is possible to use two types of sensors, either Pt100/2-wire or Pt100/3-wire. Optional display of °C or °F values. In case of use of a Pt100/2-wire unit the actual temperature value can be corrected. Range +/- 10K or +/-18F, respectively. In case of use of a Pt100/3-wire unit the temperature is automatically corrected. Also suitable for use with ELTF-PTEx 1 and 2 sensor.

Relay configuration: relay 1: regulator, relay 2: alarm / temperature reached

Temperature alarm: If the actual value deviates from the preset limit values, an alarm is given and transmitted via alarm relay K2.

Type ELTC-14



Type	Designation	Art. No.
ELTC-14	Standard: Set with cable glands, reducer and blind cover	0620000

Electronic Temperature Controller

The ELTC-21 is an electronic temperature controller with digital display for top-hat rail mounting. The temperature is measured by a Pt100 sensor, processed by the microcontroller and displayed. After having evaluated the actual and preset values, the appropriate output relays are switched, depending on the configuration.

Advantages:

- LED display operable down to $-25\text{ }^{\circ}\text{C}$
- Programmable $-50\text{ }^{\circ}\text{C}$ up to $+400\text{ }^{\circ}\text{C}$
- For switching 16 A resistive load
- Alarm contact
- Pt100 with 2 or 3 wires

Applications:

- Industrial applications
- Mechanical, electrical and plumbing (MEP)

Technical Information

Data

■ Operating voltage	230 V
■ Power consumption	Max. 4 mA, < 5 W
■ Switching capacity, relay 1	16 A close contact (heating)
■ Switching capacity, relay 2	8 A, changeover contact (alarm)
■ Operating temperature	-25 up to $+55\text{ }^{\circ}\text{C}$
■ Storage temperature	-25 up to $+60\text{ }^{\circ}\text{C}$
■ Temperature range	0 up to $+400\text{ }^{\circ}\text{C}$, opt. configuration
■ Sensor connection	Pt100 2-wires, 3-wires, opt. configuration
■ Display	LED, red
■ IP rating	IP 20
■ Mounting	Top-hat rail
■ Dimensions [w x h x d in mm]:	51.5 x 87.5 x 58.0

Type ELTC-21

Wiring diagram

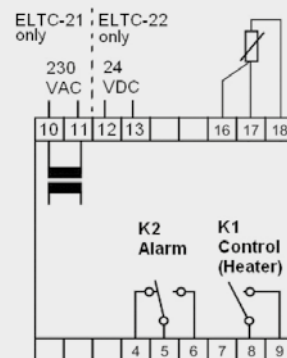

Sensors and display: It is possible to use two types of sensors, either Pt100/2-wire or Pt100/3-wire. Optional display of $^{\circ}\text{C}$ or $^{\circ}\text{F}$ values. In case of use of a Pt100/2-wire unit the actual temperature value can be corrected. Range $\pm 10\text{K}$ or $\pm 18\text{F}$, respectively. In case of use of a Pt100/3-wire unit the temperature is automatically corrected. Also suitable for use with ELTF-PTE_x 1 and 2 sensor.

Relay configuration: relay 1: regulator, relay 2: alarm

Temperature alarm: If the actual value deviates from the preset limit values, an alarm is given and transmitted via alarm relay K2.

Type ELTC-21



Type	Art. No.
ELTC-21	0610093

Electronic

Temperature Controller for 24 VDC

The ELTC-22 is an electronic temperature controller with digital display for standard rail mounting. The temperature is measured by a Pt100 sensor, processed by the microcontroller and displayed. After having evaluated the actual and preset values, the appropriate output relays are switched, depending on the configuration.

Advantages:

- LED display operable down to -25 °C
- Programmable -50 °C up to +400 °C
- For switching 16 A ohm load
- Alarm contact
- Pt100 with 2 or 3 wires

Applications:

- Industrial applications
- Mechanical, electrical and plumbing (MEP)

Technical Information

Data

■ Operating voltage	24 VDC
■ Power consumption	Max. 4 mA, < 5 W
■ Switching capacity, relay 1	16 A close contact (heating)
■ Switching capacity, relay 2	8 A, changeover contact (alarm)
■ Operating temperature	-25 up to +55 °C
■ Storage temperature	-25 up to +60 °C
■ Temperature range	0 up to +400 °C, opt. configuration
■ Sensor connection	Pt100 2-wires, 3-wires, opt. configuration
■ Display	LED, red
■ IP rating	IP 20
■ Mounting	Top-hat rail
■ Dimensions [w x h x d in mm]:	51.5 x 87.5 x 58.0

Type ELTC-22

Wiring diagram

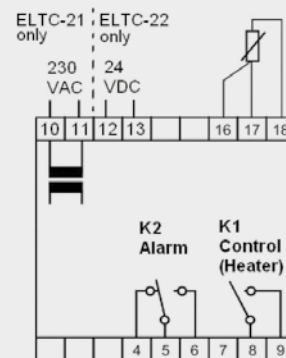

Sensors and display: It is possible to use two types of sensors, either Pt100/2-wire or Pt100/3-wire. Optional display of °C or °F values. In case of use of a Pt100/2-wire unit the actual temperature value can be corrected. Range +/- 10K or +/-18F, respectively. In case of use of a Pt100/3-wire unit the temperature is automatically corrected. Also suitable for use with ELTF-PTEX 1 and 2 sensor.

Relay configuration: relay 1: regulator, relay 2: alarm

Temperature alarm: If the actual value deviates from the preset limit values, an alarm is given and transmitted via alarm relay K2.

Type ELTC-22



ELC

Type	Art. No.
ELTC-22	0610094

Junction Box

Round, for Wall-mounting

This innovative junction box provides a lot of advantages. Due to the shape of the box, for instance, it is not necessary to strongly bend the inserted cable thereby avoiding cable damage.

The unique snap fit permits rapid closing of the cover without needing a special tool. A safety lock, with appropriate tool included, prevents the cover from moving. Additional features permit the attachment of sign plates facilitating easy identification of heating circuits in complex systems.

Advantages:

- Rapid closing of the cover through snap fit, no tool required
- Increased mechanical safety through round shape
- Permits fixing of customer identification plates
- Up to 3 heating cables can be connected

Applications:

- Chemical & petrochemical industries
- Power stations
- Industrial plants with a need for frost protection or temperature maintenance



Type **ELAK-R**





Technical Information

Data

■ Ambient temperature	-45°C up to +50°C
■ Nominal current	See type plate, max. 28 A each terminal 6 mm ²
■ Nominal voltage	See type plate, max. 800 VAC
■ Terminals heating cable	Max. 6 mm ² / AWG 10
■ Terminals temperature sensor	Max 1.5 mm ² / AWG 16
■ Enclosure	Polyamide, RAL 7043 traffic grey
■ Dimensions (approx.):	Dia. 150 mm, height 125 mm
■ Cable glands	Polyamide
■ IP rating	IP65
■ Weight	Approx. 0.7 kg

Type ELAK-R

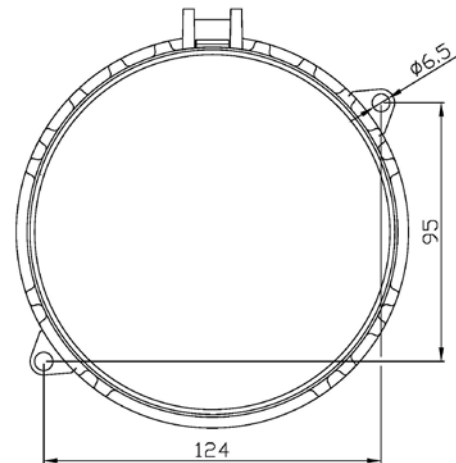

Type	Application	Features	Item n°
ELAK-R-7	Supply: 1 to 3 self-regulating heating cables ELSR	wall-mounting, 1x M25 (9-17), 1 x bore hole M25, 2 x bore holes with thread plug M25 *	0920057
ELAK-R-8	Connection of up to 2 Pt100, 2 to 4 conductors + up to 2 sensor lines max 2.5 mm ²	1x M25 (9-17), 1 x M16 (3-7), 1 x M16 (3-7) with blind plugs, 1 x bore hole with thread plug M25 *	0920058

Note: Connection and termination kits are not included in the ELAK-R system. Please place a separate order for these items which depend on the type of heating cable used.

Junction Box

Round, with Mounting Bracket for On-pipe-mounting

This innovative junction box provides a number of advantages. Thanks to the shape of the box, for instance, it is not necessary to strongly bend the inserted cable thereby avoiding cable damage.

Due to the incorporated mounting bracket, there is no need to provide angle irons. This is especially advantageous to heat tracing on pipework because cable entry is directly put through the mounting bracket. Furthermore, fastening screws for heating lines and sensors are not required. The unique snap fit permits rapid closing of the cover without needing a special tool. A safety lock, with appropriate tool included, prevents the cover from moving. Additional features permitting the attachment of sign plates facilitate easy identification of heating circuits in complex systems.

Advantages:

- Integrated mounting bracket
- Rapid closing of the cover through snap fit, no tool required
- Increased mechanical safety through round shape
- Permits fixing of customer identification plates
- Up to 3 heating cables can be connected

Applications:

- Industrial plants with a need for frost protection or temperature maintenance



Type ELAK-RS





Technical Information

Type ELAK-RS

Data

■ Ambient temperature	-45°C up to +50°C
■ Nominal current	See type plate, max. 32 A each terminal 6 mm ²
■ Nominal voltage	See type plate, max. 800 VAC
■ Terminals heating cable	Max. 6 mm ² / AWG 10
■ Terminals temperature sensor	Max 1.5 mm ² / AWG 16
■ Enclosure	Polyamide, RAL 7043 traffic grey
■ Dimensions (approx.):	Dia. 150 mm, 125 x 160 mm
■ ELAK-RS	Height approx. 280 mm total, the junction box is attached to the mounting feet.
■ Cable glands	Polyamide
■ IP rating	IP65
■ Weight	Approx. 0.7 kg

Mounting Bracket

■ Operating temperature	Up to 200 °C
■ Enclosure material	PPS
■ Insulation thickness, max	100 mm
■ Pipe outer diameter	≥ NW 3/4" / AD 20 mm
■ IP rating	IP65

Type	Item n°	Application	Features
ELAK-RS	0920050	Supply: 1 to 3 heating cables ELSR-N, -H, connection Pt100	including bracket for on-pipe-mounting 1x M25 (9-17), 1x M20 with blind plug*
ELAK-RS-T	0920059	T-splice ELSR-N, -H	including bracket for on-pipe-mounting
ELAK-RS-Pt	0920060	Connection of 1 Pt100 2-4 cables & sensor lines max. 2.5 mm ²	including bracket for on-pipe-mounting 1x M20 (6-13), 1 bore hole with blind plug M25

Note: Connection and termination kits are not included in the ELAK-R system. Please place a separate order for these items which depend on the type of heating cable used.

Connection Kit

for Self-regulating Heating Cables

These connection kits have specially been developed to ensure a quick, easy and safe connection of our self-regulating heating cables ELSR in non-hazardous locations.

Advantages:

- Easy termination
- Time-saving

Applications:

- Pipe heating
- Frost protection
- Temperature maintenance on pipes and drums
- Paint and varnish
- Food industry



Type ELVB-SRA...-25



ELVB-SRA-25



Technical Information

Data

- Permissible ambient temperature 100 °C
- Protection class IP66

ELVB-SRAM-20



ELVB-SRAR-25



ELVB-SRAH-25



Type	Cable glands	suitable for	Art.-No.
ELVB-SRA-25	M25 x 1,5, PE gland	ELSR-N, -LS, -W, -FHP	091A010
ELVB-SRAM-25	M25 x 1,5, PE gland	suitable for ELSR-M	091A015
ELVB-SRAR-25	M25 x 1,5, PE gland	suitable for ELSR-R	091A020
ELVB-SRAH-25	M25 x 1,5, PE gland	suitable for ELSR-H	091A040

All articles including termination instruction.

End Termination Kits

for Self-regulating Heating Cables

These end termination kits for eltherm self-regulating heating cables are available in different versions, each suitable to our low temperature and middle temperature heating cables.

The end termination kit EL-ECMF for our heating cable ELSR-M-10-BF is KTW certified and can be used inside potable water lines.

Advantages:

- Easy termination
- Time-saving

Applications:

- Pipe heating
- Frost protection
- Temperature maintenance on pipes and drums
- Paint and varnish
- Food industry



Type **EL-ECN/L/M/MF/W**





Technical Information

Data

- Permissible ambient temperature -60 bis 100 °C

EL-ECN



EL-ECL



EL-ECW



EL-ECM

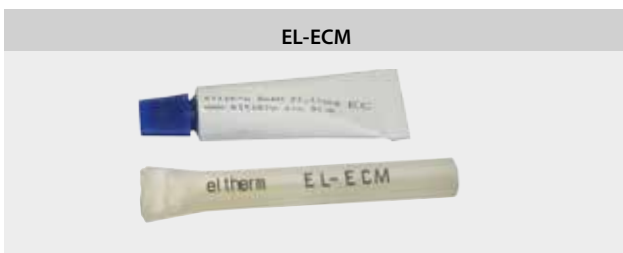

EL-ECMF



Type	End cap	Glue	Suitable for	Art.-No.
EL-ECN	Silicone, transparent	Silicone glue „LT“, 5 g tube, blue screw cap, transparent glue	ELSR-N	09112N1
EL-ECL	Silicone, transparent	Silicone glue „LT“, 5 g tube, blue screw cap, transparent glue	ELSR-LS	09112L1
EL-ECM	Silicone, transparent	Silicone glue „LT“, 5 g tube, blue screw cap, transparent glue	ELSR-M/R	09112M1
EL-ECMF	Silicone, transparent certified for potable water	Silicone glue „LT“, 5 g tube, blue screw cap, transparent glue	ELSR-M-BF / AF	09112MF
EL-ECW	Silicone, transparent	Silicone glue „LT“, 5 g tube, blue screw cap, transparent glue	ELSR-W	09112W1

All articles including termination instruction.

Fast Connection and Power Termination

No matter if you want to connect a self-regulating heating cable (types ELSR-N, -LS or -W) with the power supply, you need a Tee-splice, you want to supply two or three self-regulating heating cables with power, just connect two or three self-regulating heating cables to each other, with the innovative fast connector system El-Clic you have the perfect solution. One device covers all applications.

You no longer need to keep different fast connectors on stock – El-Clic is “All in one”.

You can realise remarkable cost-savings by optimized stock. With El-Clic you have enormous flexibility on site because unexpected situations are no longer a problem. With El-Clic, you always have the right power supply and connector on-hand.

In the El-Clic P version the connector comes ready-made with extra long supply lead. The version El-Clic S is available as pure connector for up to three heating cables without supply lead.

Connection and power termination of the heating cables can be done quick and easy, the only tools required are a screwdriver and a cutter. This time saving allows remarkable reduction of installation costs.

El-Clic is designed without any losable small parts, so installation can be done faster and safe. A screw prevents accidental opening of the enclosure.

Either wall mounting or on-pipe mounting can be done without need of additional supports or clamps. For on-pipe mounting you will find two temperature and UV resistant cable straps included. (Please have suitable screws in store for wall mounting.) Furthermore, El-Clic is designed compact and really a lightweight.

Type **El-Clic**



Certified according
to VDE standards



Technical Information

Advantages

- Only one connection box for all applications
- Space-saving storage
- No losable small parts
- Compact design
- Low weight
- Quick, safe and easy installation
- Highest flexibility on site
- Perfect for on-pipe-mounting due to integrated supporting feet
- No additional supports or clamps needed for wall mounting and on-pipe mounting
- Prevention of accidental opening
- Extra long supply lead

Data

■ Nominal Voltage	230 V
■ Nominal Current	16 A
■ Ambient temperature	- 40° C up to + 100 °C
■ Casing material	UV resistant Polyamid
■ IP-rating	IP 65
■ Approval	VDE
■ Dimensions (lxwxh)	19x7x5 cm
■ Weight, approx.	500 g (with cold lead)
■ Tools required	Screwdriver
■ Supply lead	2.5 m (El-Clic P)
■ Cable tie	2 pcs 360 mm, UV resistant
■ VDE mark	40037869



Installation is done fast and easy: a screwdriver is the only tool required (according to installation situation)!

Type	Description	Art.-No.
El-Clic P	Factory terminated, with supply lead for ELSR-N, -LS, -W	09ClicP
El-Clic S	Without supply lead for ELSR-N, -LS, -W	09ClicS

Termination kits for ELSR-N, -LS, -W:
please order separately

Junction Box, Round, with Mounting Stand On-pipe Mounting in Hazardous Areas



The innovative junction box ELAK-Ex-R with mounting bracket (Ex-it) is suitable for use in potentially explosive atmosphere in accordance with Ex-guidelines 94/9/CE (ATEX 95) and provides a number of advantages. Thanks to the shape of the box, for instance, it is not necessary to strongly bend the inserted cable thereby avoiding cable damage. Due to the incorporated mounting bracket, there is no need to provide angle irons. This is especially advantageous to heat tracing on piping because the cable can directly be introduced via the mounting bracket. Furthermore, fastening screws for heating lines and sensors are not required. A safety locking, with appropriate tool included, prevents the cover from moving. Additional features permitting the attachment of sign plates facilitate easy identification of heating circuits in complex systems.

Advantages:

- No static charge
- Rapid closing of the cover through snap fit, no tool required
- Increased mechanical safety through round shape
- Permits fixing of customer identification plates
- Up to 3 heating cables can be connected

Applications:

- Hazardous areas
- Chemical & petrochemical industries
- Power stations
- Industrial plants with a need for frost protection or temperature maintenance



Type **Ex-it-R**





Technical Information

Type Ex-it-R

Data

■ Classification ELAK-Ex-R	II 2G Ex e IIC T6 Gb II 2D Ex tb IIC TX Db
■ Classification Ex-it-R	II 2G Ex e IIC Gb II 2D Ex tb IIC Db
■ Standards Ex-it-R	IEC 60079-0 ed.6, IEC 60079-7 ed.4, IEC 60079-31 ed.1
■ Ambient temperature	-40°C up to +50°C
■ Enclosure	Polyamide, no static charge
■ Dimensions (approx.):	Dia. 150 mm, 125 x 160 mm
■ Ex-it-R	Height approx. 280 mm total, the junction box is attached to the mounting feet.
■ Impact resistance	7 Joule
■ IP rating	IP 65
■ Terminal blocks, heating cable connection:	max. 6 mm ²
■ Terminal blocks, temperature sensor connection:	max. 1.5 mm ²

Mounting bracket

■ Working temperature	-20°C up to +200°C
■ Enclosure	PPS
■ Insulating thickness, max	120 mm
■ Pipe outer diameter	≥ 20 mm
■ IP rating	IP 65
■ Classification	II 2G Ex e II 2 D Ex tD A21 IP65
■ Certificate	IBExU09ATEX1023U

Type	Description	Art. No.
Ex-it-R	Junction Box, with mounting feet, round, dia. 150 mm, height 125 mm, polyamide enclosure, to connect 3 self-regulating heating cables ELSR-N/-H, 1 connecting cable, 1 sensor cable, 1 double-Pt100, insulating thickness max. 100 mm	0X80070
Ex-it-R-T	T-branch, with mounting feet, round, dia.150 mm, height 125 mm, polyamide enclosure, to connect up to 3 self-regulating heating cables ELSR-N/-H, insulating thickness max.100 mm	0X80082
Ex-it-R-Pt	Junction Box, with mounting feet, round, dia. 150 mm, height 125 mm, polyamide enclosure, to connect 1 double-Pt100, 1 sensor cable, insulating thickness max. 100 mm	0X80092

Note: Connection and termination kits are not included in the Ex-it-R system. Please place a separate order for these items which depend on the type of heating cable used.

Junction Box, Round for Hazardous Areas



The innovative junction box ELAK-Ex-R is suitable for use in potentially explosive atmosphere in accordance with Ex-guidelines 94/9/CE (ATEX 95). Thanks to its exceptional shape it provides a number of advantages. Due to the form of the box, for instance, it is not necessary to strongly bend the inserted cable thereby avoiding cable damage.

A safety lock, with appropriate tool included, prevents the cover from moving. Additional features permitting the attachment of sign plates facilitate easy identification of heating circuits in complex systems. Suited for wall-mounting.

Advantages:

- No static charge
- Rapid closing of the cover through snap fit, no tool required
- Increased mechanical safety through round shape
- Permits fixing of customer identification plates
- Up to 3 heating cables can be connected

Applications:

- Hazardous areas
- Chemical & petrochemical industries
- Power stations
- Industrial plants with a need for frost protection or temperature maintenance



Type ELAK-Ex-R





Technical Information

Type ELAK-Ex-R

Data

■ Classification	II 2G Ex e IIC T6 Gb II 2D Ex tb IIIC TX Db
■ Standards	IEC 60079-0 ed.6, IEC 60079-7 ed.4, IEC 60079-31 ed.1
■ Ambient temperature	-40 °C up to +50 °C
■ Nominal current	See type plate, max. 28 A each terminal
■ Nominal voltage	See type plate, max. 550V
■ Terminals heating cable	Max. 6 mm ² (optional 10 mm ²)
■ Terminals temp.sensor (if required)	Max. 1.5 mm ²
■ Enclosure	Polyamide, no static charge
■ Dimensions (approx.)	Ø 150 mm, height 125 mm
■ Impact resistance	7 Joule
■ Cable glands	Polyamide
■ IP rating	IP65
■ Weight	Approx. 0.7 kg
■ Type of mounting	Wall-mounting

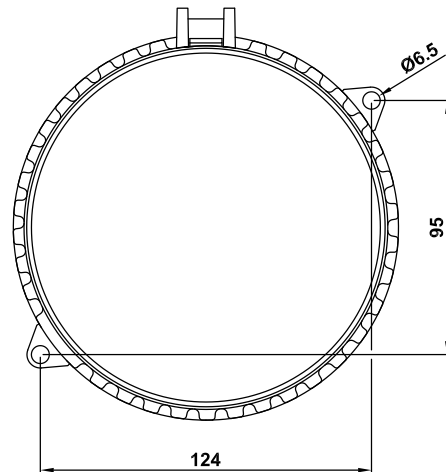

Type	Application	Features	Art. No.
ELAK-Ex-R5	Supply: 1 heating cable ELSR... + EL-CT	dia. 150 mm, height 125 mm, polyamide enclosure, for ELSR + EL-CT, Ex e	0X80075
ELAK-Ex-R7	Supply: 1-3 heating cable ELSR...	1 x M25 (8-17 mm), 2 x threaded plug M25, 1 x Bohrung M25	0X80077
ELAK-Ex-R8	Supply: 1-2 Pt 100, 2-4 conductors + up to 2 sensor lines max. 2.5 mm ²	1 x M25 (8-17 mm), 1 x M16 (4-9 mm), 2 x threaded plug M16, 1 x threaded plug M20	0X80078

Note: Connection and termination kits are not included in the ELAK-Ex-R-system. Please place a separate order for these items which depend on the type of heating cable used.

Junction Box

for Hazardous Areas



This junction box ELAK-Ex-3 in conventional design is suitable for use in potentially explosive atmosphere in accordance with Ex-guidelines 94/9/CE (ATEX 95). Moreover, the unit ELAK-Ex-3 covers a significantly wide range of ambient temperatures as shown on the data sheet. The junction box can be wall-mounted and is also available with stands for mounting on pipes.

Advantages:

- Covers a wide range of temperatures
- Suited for mounting on pipes

Applications:

- Hazardous areas
- Chemical & petrochemical industries
- Power stations
- Industrial plants with a need for frost protection or temperature maintenance



Type **ELAK-Ex-3**





Technical Information

Type ELAK-Ex-3

Data

■ Classification	II 2G Ex e IIC T6...T4 Gb II 2D Ex tb IIIC T80 °C Db
■ Certificate	EPS13 ATEX 1506X, IECEX EPS 13.0002
■ Standards	EN 60079-0:2009, EN 60079-7:2007, EN 60079-31:2009
■ Ambient temperature	-40 °C up to +50 °C (T6, T85 °C) -40 °C up to +55 °C (T5, T100 °C) -40 °C up to +60 °C (T4, T100 °C)
■ Nominal current	See type plate, max. 36 A
■ Nominal voltage	See type plate, max. 550V
■ Terminals	Min. 0.5 mm ² , max. 10 mm ² (except ELAK-Ex-3.8)
■ Enclosure	Polyester
■ Dimensions (approx.)	l x h x d 122 x 120 x 90 mm
■ Impact resistance	7 Joule
■ Cable glands	Polyamide
■ IP rating	IP65 / 66 depending on design
■ Weight	Approx. 1 kg
■ Type of mounting	Wall-mounting

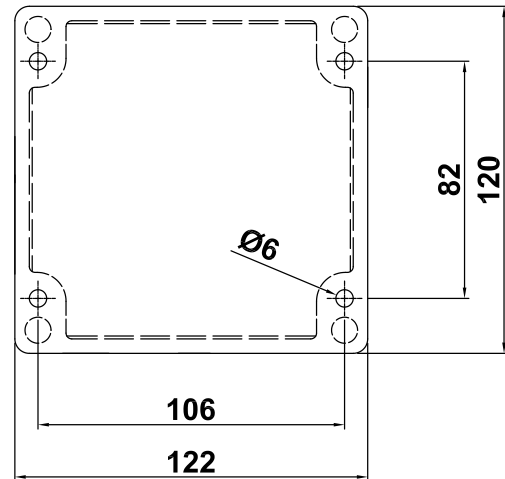

The ELAK-Ex-3 unit fitted with the mounting stand ELMW-9 (122 x 120 – Art. No. 0941009) is also suited for mounting on pipes. The mounting stand is 100 mm high.

Type	Application	Features	Art. No.
ELAK-Ex-3.5	Supply: 1 heating cable ELSR-... + EL-CT	122 x 120 x 90 mm, polyester enclosure, for ELSR + EL-CT, Ex e	0X80055
ELAK-Ex-3.7	Supply: 1-3 heating cable ELSR-...	1 x M25 (7-17 mm), 2 x threaded plug M25, 1 x bore hole M25	0X80057
ELAK-Ex-3.8	Supply 1-2 Pt 100, 2-4 wire + up to 2 conductors + up to 2 sensor lines max 2.5 mm ²	1 x M25 (7-17 mm), 1 x threaded plug M25, 1 x M16 (3-6 mm), 2 x threaded plug M16	0X80058

Note: Connection and termination kits are not included in the ELAK-Ex-3-system. Please place a separate order for these items which depend on the type of heating cable used.

Connection Kits



for Self-regulating Heating Cables

These connection kits for eltherm® self-regulation heating cables have specially been developed for use in hazardous areas, Ex e.

Advantages:

- Easy termination
- Time-saving

Applications:

- Pipe heating
- Frost protection for industrial plants
- Hazardous areas
- Chemical and petrochemical plants
- Oil and gas industry
- Container and tanks
- Food industry



ELVB-SR...Ex-...



ELVB-SREx-25



Technical Information

Data

■ Classification	III 2G Ex e IIC Gb II 2D Ex tb IIIC Db II 2G Ex db e IIC Gb II 1D Ex ta IIIC Da (ELVB.SRA...-Ex-20)
■ Directives	EN 60079-7, -31; IEC 60079-7, -31; IEEE 515 + CSA 130-3
■ Permissible ambient temperature	-55 °C up to +70 °C (in case of protected installation) -25 °C up to +70 °C (in case of higher grade of mechanical stress) -60 °C up to +80 °C (ELVB-SRA...-Ex-20)
■ Certificates	IBExU07ATEX1022X SIRA01ATEX1270X (ELVB.SRA...-Ex-20)

ELVB-SRAH-Ex-20



ELVB-SRAN-Ex-20 / ELVB-SRAL-Ex-20



ELVB-SREx-IT



Type	Cable glands	Glue	Suitable for	Art.-No.
ELVB-SREx-25	M25 x 1,5 PE gland (black)	Silicone glue „LT“, 5 g tube, blue screw cap, transparent glue	ELSR-N, -LS, -H, -FHP	0X81PA1
ELVB-SREx-IT		Silicone glue „LT“, 5 g tube, blue screw cap, transparent glue	ELSR-N, -H for Mounting post Ex-it-R	091AIT1
ELVB-SRAN-Ex-20	M20, brass	Silicone glue „LT“, 5 g tube, blue screw cap, transparent glue	ELSR-N, -FHP	0X81PND
ELVB-SRAL-Ex-20	M20, brass	Silicone glue „LT“, 5 g tube, blue screw cap, transparent glue	ELSR-LS	0X81PLD
ELVB-SRAH-Ex-20	M20, brass	Silicone glue „HT“, 5 g tube, red screw cap, red glue	ELSR-H	0X81PHD

All articles including termination instruction.



End Termination Kits

for Self-regulating Heating Cables

These end termination kits for eltherm® self-regulation heating cables have specially been developed for use in hazardous areas.

We offer several custom-fit end termination kits for our low temperature and a special kit for our high temperature heating cables.

Advantages:

- Easy termination
- Time-saving

Applications:

- Pipe heating
- Frost protection for industrial plants
- Hazardous areas
- Chemical and petrochemical plants
- Oil and gas industry
- Container and tanks
- Food industry



Type **EL-ECN/L/H-Ex**





Technical Information

Data

■ Classification	II 2G Ex e IIC Gb II 2D Ex tb IIIC Db
■ Directives	EN 60079-7, -31; IEC 60079-7, -31; IEEE 515 + CSA 130-3
■ Permissible ambient temperature	-45 to 85 °C, EL-ECN-Ex -45 to 85 °C, EL-ECL-Ex -40 to 210 °C, EL-ECH-Ex
■ Certificates	IECEX IBE 12.0001U, 05ATEX1154U

EL-ECN-Ex:



EL-ECL-Ex:



EL-ECH-Ex:



Type	End cap	Glue	suitable for	Art.-No.
EL-ECN-Ex	Silicone, transparent, with Ex-imprint	Silicone glue „LT“, 5 g tube, blue screw cap, transparent glue	ELSR-N up to 80°C	OX81EN1
EL-ECL-Ex	Silicone, transparent, with Ex-imprint	Silicone glue „LT“, 5 g tube, blue screw cap, transparent glue	ELSR-LS up to 80°C	OX81EL1
EL-ECH-Ex	Silicone, transparent, with Ex-imprint	Silicone glue „HT“, 5 g tube, red screw cap, red glue	ELSR-H up to 210°C	OX81EH1

Self-regulating Heating Cables

Accessories

1	Designation	Description	Art. No.							
				ELSR-N	ELSR-LS	ELSR-M	ELSR-R	ELSR-W	ELSR-H	☒-suitable
		Connection Kits								
	ELVB-SRA-25	Connection kit for ELSR-N, -L, -W and -FHP	091A010	■	■				■	
	ELVB-SRAM-25	Connection kit for ELSR-M	091A015			■				
	ELVB-SRAR-25	Connection kit for ELSR-R	091A020				■			
	ELVB-SRAH-25	Connection kit for ELSR-H	091A040						■	
	ELVB-70	Cable gland 3/4" for water pipe for ELSR-M-...-BF/AF	0911703			■				
	ELVB-71	Y-piece, 32mm for installation in PE pipes AD 32 for ELSR-M-...-BF/AF	0911704			■				
	ELBV-BF	Connection kit for ELSR-M -...-BF , without cable gland	0911022			■				
	☒ ELVB-SREx-25	Connection kit ELSR-N, -LS, -H, -FHP, M25, Ex e	0X81PA1	■	■				■	■
	☒ ELVB-SREx-IT	Connection kit ELSR-N and -H, for use with Ex-it-R	091AIT1	■					■	■
	☒ ELVB-SRAN-Ex-20	Connection kit ELSR-N, -FHP, M20 Ms, Ex d	0X81PND	■						■
	☒ ELVB-SRAL-Ex-20	Connection kit ELSR-LS M20 Ms, Ex d	0X81PLD		■					■
	☒ ELVB-SRAH-Ex-20	Connection kit ELSR-H M20 Ms, Ex d	0X81PHD						■	■

2	Designation	Description	Art. No.							
				ELSR-N	ELSR-LS	ELSR-M	ELSR-R	ELSR-W	ELSR-H	☒-suitable
		Termination Kits								
	EL-ECN	Termination kit for ELSR-N	09112N1	■						
	EL-ECL	Termination kit for ELSR-LS	09112L1		■					
	EL-ECMF	Termination kit for ELSR-M-...-BF/AF	09112MF			■				
	EL-ECW	Termination kit for ELSR-W	09112W1					■		
	EL-ECM	Termination kit for ELSR-M and -R	09112M1			■	■			
	☒ EL-ECN-ex	Termination kit Ex for ELSR-N, Ex e	0X81EN1	■						■
	☒ EL-ECL-ex	Termination kit Ex for ELSR-LS, Ex e	0X81EL1		■					■
	☒ EL-ECH-ex	Termination kit Ex for ELSR-H, Ex e	0X81EH1						■	■
	EL-ECRA	EL-ECRA termination kit for ELSR-Ramp	09112RA							

Measuring, controlling and monitoring technology, electronic temperature controllers, electronic heating circuit monitoring device temperature sensors and thermocouples

Please refer to our wide product portfolio, 'Measurement and Control'

Key: ■ suitable, □ partially suitable



Accessories

3

Designation	Description	Art. No.	ELSR-N	ELSR-LS	ELSR-M	ELSR-R	ELSR-W	ELSR-H	☉-suitable
	Connection Kits								
ELVB-SRV-N-L-W	Connection kit ELSR-N, ELSR-LS and ELSR-W, heat-shrink technique	0911116	■	■			■		
ELVB-SRV-H	Connection kit ELSR-H	0911117						■	
ELVB-SRV-M	Connection kit ELSR-M	0911122			■				
☉ Ex-Con-SR	Ex bushing for hazardous areas, conductor section 3 x 1.5 mm ² and 3 x 2.5 mm ² , length 210 mm, 4J, suitable for ELSR-N and H	0X81125	■	■				■	■
ELVB-SRV-Ramp	Connection kit ELSR-Ramp for repair and connection on the hose	0911124							

4

Designation	Description	Art. No.	ELSR-N	ELSR-LS	ELSR-M	ELSR-R	ELSR-W	ELSR-H	☉-suitable
	Junction boxes								
ELAK-2	Junction box, 98 x 98 x 58 mm, thermoplastic enclosure	0920001	■	■	■	■	■		
ELAK-5	Junction box, 122 x 120 x 90 mm, polyester enclosure	0920013	■	■	■	■	■	■	
ELAK-5.1	Junction box, 130 x 130 x 75 mm, polycarbonate enclosure	0920002	■	■	■	■	■		
ELAK-6	Junction box, 220 x 120 x 90 mm, polyester enclosure	0920016	■	■	■	■	■	■	
ELAK-7	Junction box, 260x 160 x 90 mm, polyester enclosure	0920019	■	■	■	■	■	■	
ELAK-RS	Junction box, with mounting feet, round, dia. 150 mm, height 125 mm, thermoplast, max. temperature 200 °C, to connect 3 self-regulating heating cables ELSR-N/-H, 1 connecting cable, 1 sensor cable, 1 double Pt100, insulating thickness max. 100 mm	0920050	■	■			■		
ELAK-RS-T	T branch, round, dia. 150 mm, height 125 mm, max. 200 °C, to connect up to 3 self-regulating heating cables ELSR-N/-H, insulating thickness max. 100 mm	0920059	■	■			■		
ELAK-RS-Pt	Junction box, with mounting feet, round, dia. 150 mm, height 125 mm, thermoplastic enclosure, max. temperature 200 °C, to connect 1 double-Pt100, 1 sensor cable, insulating thickness max.100 mm	0920060							
☉ ELAK-Ex-3.5	Junction box, 122 x 120 x 90 mm, polyester enclosure, for ELSR + EL-CT, Ex e	0X80055	■	■				■	■
☉ ELAK-Ex-3.7	Junction box, 122 x 120 x 90, polyester enclosure	0X80057	■	■				■	■
☉ ELAK-Ex-5	Junction box, dia. 150 mm, height 125 mm, polyamide enclosure, for ELSR + EL-CT, Ex e	0X80075							
☉ ELAK-Ex-R7	Junction box, round, dia 150 mm, height 125 mm, polyamide enclosure	0X80077	■	■				■	■
☉ Ex-it-R	Junction box, with mounting feet, round, dia. 150 mm, height 125 mm, polyamide enclosure, to connect 3 self-regulating heating cables ELSR-N/-H, 1 connecting cable, 1 sensor cable, 1 double-Pt100, insulating thickness max. 100 mm	0X80070	■					■	■
☉ Ex-it-R-T	T-branch, with mounting feet, round, dia.150 mm, height 125 mm, polyamide enclosure, to connect up to 3 self-regulating heating cables ELSR-N/-H, insulating thickness max.100 mm	0X80082	■					■	■
☉ Ex-it-R-Pt	Junction box, with mounting feet, round, dia. 150 mm, height 125 mm, polyamide enclosure, to connect 1 double-Pt100, 1 sensor cable, insulating thickness max. 100 mm	0X80092							■
El-Clc P	Fast connection and power termination for self-regulating heating cables, factory terminated, with supply lead for ELSR-N, -LS, -W	09ClcP	■	■			■		
El-Clc S	Fast connection and power termination for self-regulating heating cables, without supply lead, for ELSR-N, -LS, -W	09ClcS	■	■			■		

Self-regulating Heating Cables

Accessories

5



Pipe Mounting Fittings

Designation	Description	Art. No.	ELSR-N	ELSR-LS	ELSR-M	ELSR-R	ELSR-W	ELSR-H	☞-suitable
ELMW-5	For ELAK-2, max. insulation thickness 80 mm, mat. 1.4301/SS 304	0941005							■
ELMW-9	For ELAK-5, ELAK-Ex 3, ELTh-1, max. insulation thickness 80 mm, mat. 1.4301/SS 304	0941009							■
ELMW-11	For ELTC-14 / 05 and ELAK-5.1, max. insulation thickness 80 mm, mat. 1.4301/SS 304 a	0941011							■
ELMW-Ex-Box	Pipe mounting plate 185 x 185, mat. 1.4301/SS 304	0941072							■
ELMW-CT	For capillary thermostats Ex EL-CT..., max. insulation thickness 80 mm, mat. 1.4301/SS 304	0941025							■
ELMW-GP1	Pipe mounting fitting 175 x 125 mm	0941020							■
ELB-15.04	Stainless steel hose band clip, hose outer diameter 25/40 mm, mat. 1.4301/SS 304, (up to max. DN 25, 1")	2723001025							■
ELB-15.06	Stainless steel hose band clip, hose outer diameter 40/60 mm, mat. 1.4301/SS 304, (up a max. DN 40, 1,5")	2723001040							■
ELB-15.09	Stainless steel hose band clip, hose outer diameter 70/90 mm, mat. 1.4301/SS 304, (up to max. DN 65, 2,5")	2723001070							■
ELB-15.11	Stainless steel hose band clip, hose outer diameter 90/110 mm, mat. 1.4301/SS 304, (up to max. DN 80, 3")	2723001090							■
ELB-13V1	Threaded strap retainer, 11 mm, packaged unit = 30 m, mat. 1.4301/SS 304	2723001010							■
ELB-13V2	Tension jack for ELB-13V1, packaged unit = 10 pcs., mat. 1.4301/SS 304	0930042							■
ELB-20	Mounting bracket for downpipes, mat. 1.4301/SS 304	0930043	■						
ELB-21	Mounting bar for gutter, mat. 1.4301/SS 304	0930044	■						

6







Insulation Bushings

Designation	Description	Art. No.	ELSR-N	ELSR-LS	ELSR-M	ELSR-R	ELSR-W	ELSR-H	☞-suitable
ELISD-R1	For heating cables ELSR-N, ELSR-LS and ELSR-W, plate dimensions (alu) 70 x 70 mm	0921035	■	■			■		■
ELISD-R4	For heating cable ELSR-H, plate dimensions (alu) 70 x 70 mm	0921047						■	■
ELISD-R5	For heating cable ELSR-M, -R, plate dimensions (alu) 70 x 70 mm	0921051			■	■			■
ELISD1.12	1 x M12, plate dimensions (alu) 70 x 70 mm, insulated area for cable dia. 3.5 ... 7 mm (for connecting cables only)	0921011							■
ELISD1.16	1 x M16, plate dimensions (alu) 70 x 70 mm, dia. insulated area for cable 4.5 ... 10 mm (for connecting cables only)	0921015				■			■
ELISD1.20	1 x M20, plate dimensions (alu) 70 x 70 mm, insulated area for cable dia. 7 ... 13 mm (for connecting cables only)	0921019							■
ELISD1.25	1 x M25, plate dimensions (alu) 70 x 70 mm, insulated area for cable dia. 9 ... 17mm (for connecting cables only)	0921023							■

Key: ■ suitable, □ partially suitable



Accessories

	Designation	Description	Art. No.	ELSR-N	ELSR-LS	ELSR-M	ELSR-R	ELSR-W	ELSR-H	☺-suitable
7		Temperature Sensors								
	☺ ELTF-PTEX.2	Pt100, Ex e, 4 wires, 3 m PTFE cable	0X70002	■	■				■	■
	☺ ELTF-PTEX.4	Double-Pt100, Ex e, 3 wires, 3 m PTFE cable	0X70030	■	■				■	■
	ELTF-PT.1	Pt100, 2 wires, 5 m PVC cable	0650001	■	■	■	■	■	■	
	ELTF-PT.3	Pt100, 2 wires, 3 m PTFE cable	0650003	■	■	■	■	■	■	
	ELTF-PT.3.1	Pt100, 3 wires, 3 m PTFE cable	0650002	■	■	■	■	■	■	
8		Self-adhesive Tapes and Foil								
	ELB-02	20 m adhesive glass fibre tape, 12 mm, max. working temperature 140 °C	2486800125	■	■	■	■	■	□	■
	ELB-02A	33 m adhesive glass fibre tape, 12 mm, max. working temperature 180 °C	2486800126	■	■	■	■	■	□	■
	ELB-03	50 m adhesive glass fibre tape, 12 mm, max. working temperature 90 °C	2481800120	■	■	■	■	□	□	■
	ELB-06C	50 m self-adhesive aluminium foil, 45 mm wide, reinforced grid, max. working temperature 80 °C	2701900051	■	■	■		□	□	■
	ELB-06D	100 m self-adhesive aluminium foil, 75 mm wide, reinforced grid, max. working temperature 140 °C	2701900076	■	■	■	■	■	□	■
	ELB-06E	50 m self-adhesive aluminium foil, 536 mm wide, reinforced grid, max. working temperature 150 °C	2701900500	■	■	■	■	■	□	■
ELB-06	50 m self-adhesive aluminium foil, 75 mm wide, max. working temperature 140 °C	0942200	■	■	■	■	■	□	■	
9		Mechanical Fasteners								
	ELB-16.10	Plastic strap retainers, length 102 mm x width 2.5 mm, max. working temperature 85 °C / packaged as 100 units, UV resistant	2796000001	■	■	■	■			■
	ELB-16.20	Plastic strap retainers, length 200 mm x width 3.6 mm, max. working temperature 85 °C / packaged as 100 units, UV resistant	2796000002	■	■	■	■			■
	ELB-16.36	Plastic strap retainers, length 360 mm x width 4.8 mm, max. working temperature 85 °C / packaged as 100 units, UV resistant	2796000003	■	■	■	■			■
	ELB-18	ELB-18 mounting/fixing plate for gutter heating cables, Mat: 1.4301 / SS 304	0930040	■						
10		Warning Signs								
	EL-WS01D	German warning sign „Elektrische Begleitheizung“ *	2986900002	■	■	■	■	■	■	■
	EL-WS01E	English warning sign „Electric Heat Tracing“ *	2986900012	■	■	■	■	■	■	■
	EL-WS01F	French warning sign „Trçage Electrique“ *	2986900032	■	■	■	■	■	■	■

* also available in other languages upon request

ELSR: Application in Hazardous Areas

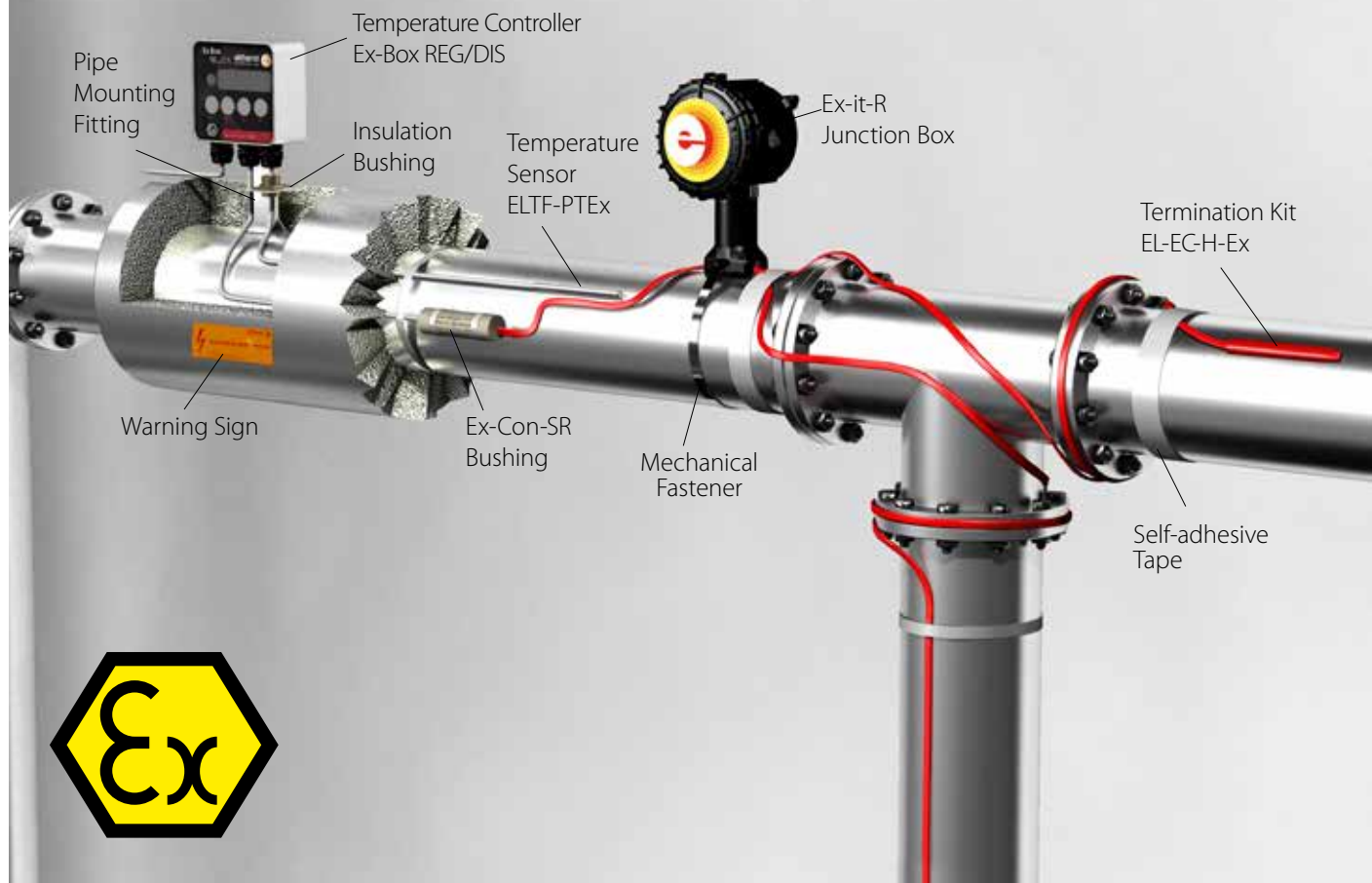

Products:

- Heating Cable ELSR-N, ELSR-LS, ELSR-H
- Measurement and Control, e. g. Ex-Box Temperature Controller
- Temperature Sensor ELTF-PTE_x
- Connection Kits, e. g. Ex-Con-SR (or ELVB...Ex...)
- Junction Boxes, e. g. Ex-it-R (or ELAK-Ex...)
- Termination Kits EL-EC...ex
- Insulation Bushings ELISD-...
- Mechanical Fasteners and/or Self-adhesive Tapes and Foil ELB-...
- Pipe Mounting Fittings ELMW-..., ELB-...
- Warning Signs EL-WS...

Remark: This is just a schematic overview, not an installation instruction. For detailed information, please contact our engineers.



ELSR: Application in Non-Hazardous Areas

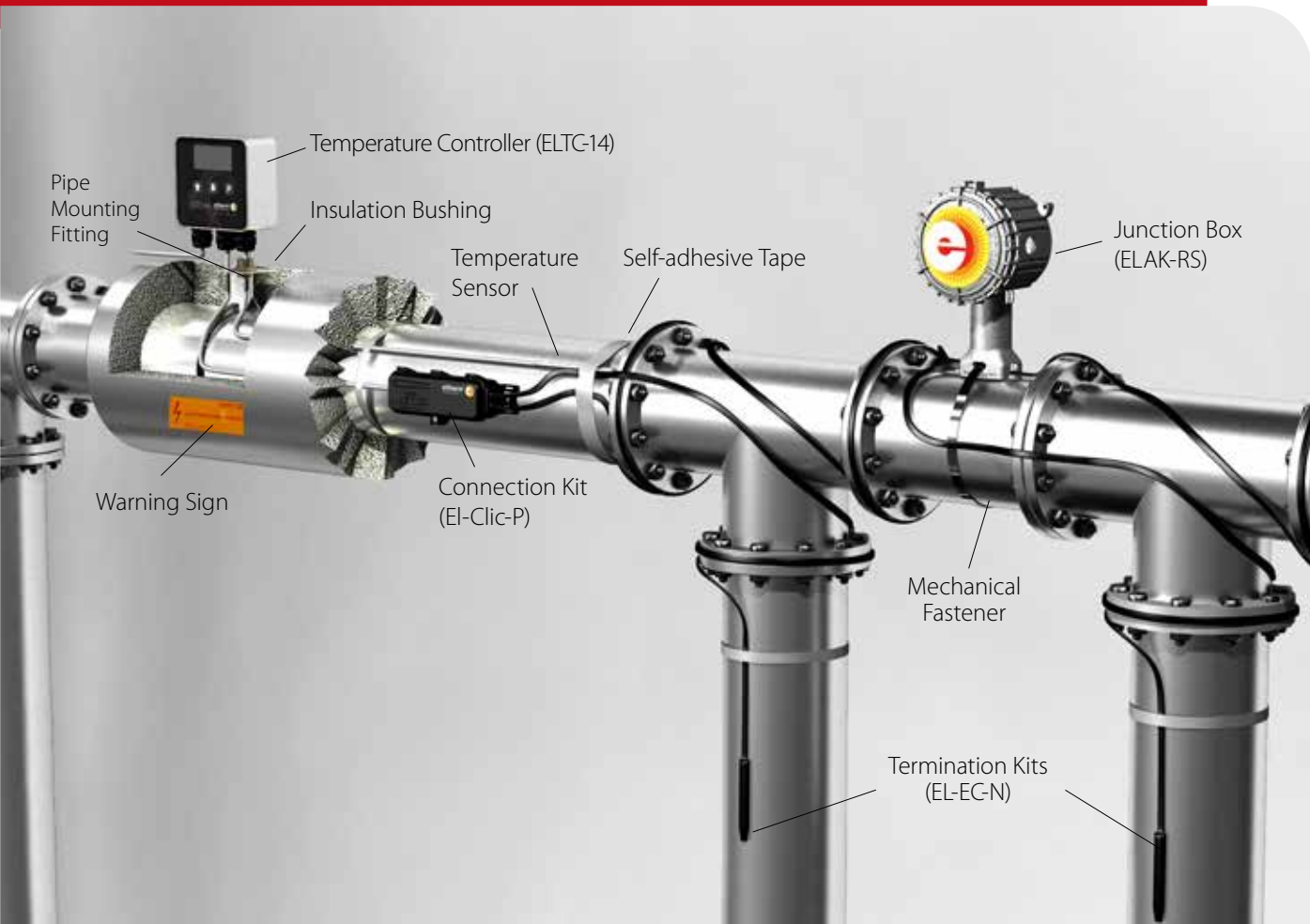

Products:

- Heating Cable ELSR-N, ELSR-LS, ELSR-M, ELSR-R, ELSR-W, ELSR-H
- Measurement and Control, e. g. ELTC-14 Temperature Controller
- Temperature Sensor ELTF-...
- Connection Kits, e. g. El-Clic-P (or ELVB-...)
- Junction Boxes, e. g. ELAK-RS
- Termination Kits EL-EC-...
- Insulation Bushings ELISD-...
- Mechanical Fasteners and/or Self-adhesive Tapes and Foil ELB-...
- Pipe Mounting Fittings ELMW-..., ELB-...
- Warning Signs EL-WS-...

Remark: This is just a schematic overview, not an installation instruction. For detailed information, please contact our engineers.

Design Guide

Table 1: Design guide frost protection +5 °C for self-regulating parallel heating cables, type series ELSR-N-10...40-2-BO(T)

Pipe size	Inches: DN	1/2 15	3/4 20	1 25	1 1/4 32	1 1/2 40	2 50	2 1/2 65	3 80	4 100	5 125	6 150	7 175	8 200	9 225	10 250	12 300
Insulation thickness (mm)	Ambient temperature, min. (°C)	Heating cable Type ELSR-N-10...40-2-BO(T)															
10	-15	10	10	20	20	20	30	30	30	40	2x30	2x30	2x40	2x40	2x40	3x30	3x40
	-20	10	20	20	20	30	30	40	40	2x30	2x30	2x40	2x40	3x30	3x40	3x40	4x40
	-25	10	20	20	30	30	40	40	2x30	2x30	2x40	2x40	3x40	3x40	4x40	4x40	4x40
20	-15	10	10	10	10	10	20	20	20	30	30	30	40	40	40	2x30	2x30
	-20	10	10	10	10	20	20	20	30	30	30	40	2x30	2x30	2x30	2x30	2x40
	-25	10	10	20	20	30	30	30	30	40	40	2x30	2x30	2x30	2x30	2x40	2x40
30	-15	10	10	10	10	10	10	10	20	20	20	20	30	30	30	40	40
	-20	10	10	10	10	10	20	20	20	20	20	20	30	40	40	40	2x30
	-25	10	10	10	10	20	20	30	20	30	30	30	40	40	2x30	2x30	2x30
40	-15	10	10	10	10	10	10	10	10	20	20	20	20	20	30	30	30
	-20	10	10	10	10	10	10	20	20	20	20	20	30	30	30	30	40
	-25	10	10	10	10	10	20	20	20	20	20	20	30	30	40	40	2x30
50	-15	10	10	10	10	10	10	10	10	10	20	20	20	20	20	20	30
	-20	10	10	10	10	10	10	10	10	20	20	20	20	30	30	30	30
	-25	10	10	10	10	10	10	20	20	20	20	20	30	30	30	30	40
60	-15	10	10	10	10	10	10	10	10	10	10	20	20	20	20	20	20
	-20	10	10	10	10	10	10	10	10	20	20	20	20	20	20	30	30
	-25	10	10	10	10	10	10	10	20	20	20	20	20	30	30	30	30
80	-15	10	10	10	10	10	10	10	10	10	10	10	20	20	20	20	20
	-20	10	10	10	10	10	10	10	10	10	10	20	20	20	20	20	20
	-25	10	10	10	10	10	10	10	10	20	20	20	20	20	20	20	30
100	-15	10	10	10	10	10	10	10	10	10	10	10	10	10	20	20	20
	-20	10	10	10	10	10	10	10	10	10	10	10	20	20	20	20	20
	-25	10	10	10	10	10	10	10	10	10	10	20	20	20	20	20	20

Basis: Thermal conductivity of the insulation 0.04 W/mK; increased factor of safety 20 %

Table 2: Heating cable additions (m) for

	DN	15	20	25	32	40	50	65	80	100	125	150	175	200	225	250	300
Pair of flanges		0.2	0.2	0.25	0.3	0.3	0.35	0.4	0.5	0.6	0.7	0.8	0.9	1.0	1.1	1.3	1.5
Flanged fitting		0.4	0.45	0.5	0.55	0.6	0.8	0.9	1.1	1.5	2.0	2.4	2.8	3.3	3.8	4.2	5.0
Pumps		1.5	1.5	2.0	2.0	2.5	2.5	3.0	4.0	5.0	5.0	6.0	6.0	6.5	6.5	7.0	8.0

For non-insulated pipe supports: Heating pipe allowance = **4 x support width**. Per heating pipe connection in the terminal box / thermostat: Heating pipe allowance **approx. 0.5 m**. **Attention:** If there is multiple laying of the heating pipes, the allowances above must be correspondingly multiplied.

Example 1:

Task: Frost protection for a **DN 100, 25 m** long pipeline with **2 pairs of flanges, 1 fitting, 1 pump, 4 supports 0.1 m wide**; at an ambient temperature of **-25 °C** and with a **50 mm** thick **heat insulation**, 230 V.

Design:	from table 1:	Heating cable type ELSR-N-20-BO, single laying	
		Pipeline length: 25 m single laying = m	= 25.0 m
	from table 2:	Pair of flanges 2 x 0,6 m	= 1.2 m
		Fitting 1 off x 1.5 m	= 1.5 m
		Pump 1 off x 5.0 m	= 5.0 m
		Pipe support 4 off x 0.1 m x 4	= 1.6 m
		Connection 1 off x 0.5 m	= 0.5 m
			= 34.8 m = order 35 m ELSR-N-20-2-BO



Design Guide

Table 3: Heat loss from pipelines in W/m at 10 K temperature difference

Pipe size	Inches: DN	1/2 15	3/4 20	1 25	1 1/4 32	1 1/2 40	2 50	2 1/2 65	3 80	4 100	5 125	6 150	7 175	8 200	9 225	10 250	12 300
Insulation thickness (mm)	DELTA T																
10	10	4.4	5.2	6.1	7.8	8.7	10.5	12.9	14.8	18.6	22.3	26.6	30.3	34.1	37.8	41.9	49.3
20	10	2.9	3.3	3.7	4.5	5.0	5.9	7.1	8.1	10.0	11.9	14.1	16	17.8	19.7	21.9	25.6
30	10	2.2	2.6	2.9	3.4	3.7	4.2	5.2	5.8	7.1	8.4	9.8	11.1	12.4	13.7	15.1	17.6
40	10	1.9	2.2	2.5	2.8	3.1	3.5	4.2	4.7	5.7	6.6	7.7	8.7	9.6	10.6	11.7	13.6
50	10	1.7	2.0	2.2	2.5	2.7	3.0	3.6	4.0	4.8	5.6	6.4	7.2	8.0	8.8	9.6	11.2
60	10	1.6	1.8	2.0	2.2	2.4	2.7	3.2	3.6	4.2	4.9	5.6	6.2	6.9	7.5	8.2	9.5
80	10	1.4	1.6	1.7	1.9	2.1	2.3	2.7	3.0	3.4	3.9	4.5	5.0	5.5	6.0	6.5	7.5
100	10	1.3	1.4	1.5	1.7	1.8	2.0	2.4	2.6	3.0	3.4	3.8	4.2	4.6	5.1	5.5	6.3
120	10	1.2	1.3	1.4	1.6	1.7	1.9	2.2	2.3	2.7	3.0	3.4	3.7	4.1	4.4	4.8	5.4

Basis: Thermal conductivity of the insulation 0.04 W/mK; increased factor of safety 20 %

If there are other thermal conductivity figures, the values must be multiplied by a corresponding factor.

Example: Thermal conductivity of the insulation 0.045 W/mK $\frac{0,045 \text{ W/mK}}{0,040 \text{ W/mK}} = 1,125$

Example 2:

Task: Temperature maintenance for 15 m **DN 50** pipeline at 20 °C (caustic soda solution) at minimum ambient temperatures of -10 °C (total DELTA-T of 30 K) and a **40 mm thick heat insulation**. Installations: 2 pairs of flanges, 2 fittings, 230V.

If the heating is designed using type ELSR-N self-regulating heating cables, please proceed as follows to select the correct nominal output:

Design (from table 3): DELTA-T 10 K heat loss = 3.5 W/m. As total DELTA-T is 30 K (that is to say is 3x higher than DELTA-T in the table), the value found is multiplied by 3: 3.5 W/m x a factor of 3 = 10.5 W/m.

In the temperature output diagram on the ELSR-N data sheet, the intersection of the two lines heating output W/m = 10.5 and temperature +20 °C is between the curves (ELSR-N-10) and (ELSR-N-20). Select the heating cable with the next highest power output (ELSR-N-20). You can now proceed with the heating pipe allowance for the installations as in Example 1.

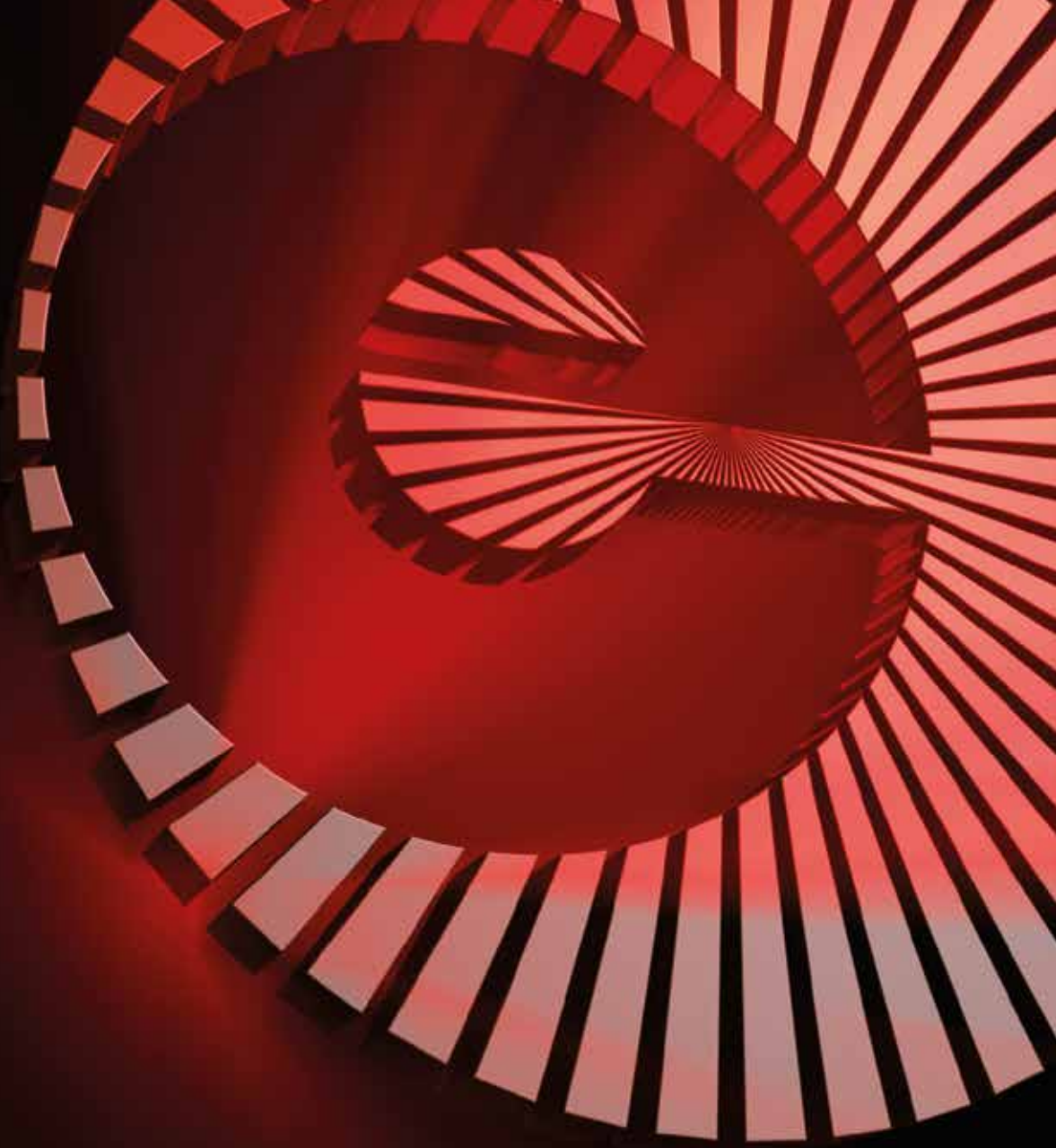

eltherm[®]
innovations in heat tracing



eltherm GmbH
Headquarters / Production site

Ernst-Heinkel-Straße 6-10
57299 Burbach, Germany

Phone +49 (0) 27 36/44 13-0
Fax +49 (0) 27 36/44 13-50

E-Mail info@eltherm.com
Web www.eltherm.com

Your reliable partner worldwide:

eltherm UK Ltd.
eltherm Spain, S.L.U.
eltherm Asia-Pacific Pte Ltd.
eltherm (Shanghai) Co., Ltd.
eltherm Canada Inc.
eltherm South Africa (Pty) Ltd.

www.eltherm.uk.com
www.eltherm.es
www.eltherm-ap.com
www.eltherm-ap.com
www.eltherm.ca
www.eltherm.co.za

innovations in heat tracing